

INSTRUCTION MANUAL
D1xH1-A & D1xH1-H Heat Detector
Class I & II Div 1 ; UL521 ; CAN/ULC-S530
NEC / CEC / ATEX / IECEx / UKEx Zone 1, 2, 21, 22

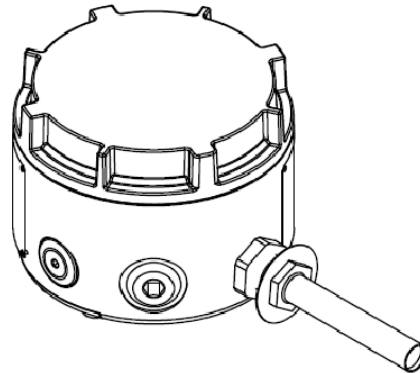

1) Product Table

Unit Type Code	Input Voltage	Max Power
D1xH1-A	125Vac 50/60 Hz / 5.0A Max	10.0W Max
	125Vdc / 0.5A Max	
	48Vdc / 1.0A Max	
	24Vdc / 2.0A Max	
D1xH1-H	125Vac 50/60 Hz / 5.0A Max	1.25W Max
	125Vdc / 0.5A Max	
	48Vdc / 1.0A Max	
	24Vdc / 2.0A Max	
Table 1: Electrical Ratings		

2) Warnings



WARNINGS:

- DO NOT OPEN WHEN AN EXPLOSIVE ATMOSPHERE IS PRESENT
- POTENTIAL ELECTROSTATIC CHARGING HAZARD - CLEAN ONLY WITH A DAMP CLOTH
- TO REDUCE THE RISK OF IGNITION OF HAZARDOUS ATMOSPHERES, THE FIRST CONDUIT RUN MUST HAVE A SEALING FITTING CONNECTED WITHIN 18 INCHES OF ENCLOSURE. SUBSEQUENT CONDUIT RUNS MUST HAVE A SEALING FITTING CONNECTED AS CLOSE AS PRACTICAL TO THE WALL OF THE ENCLOSURE, BUT IN NO CASE MORE THAN THE SIZE OF THE CONDUIT OR 50MM, WHICHEVER IS THE LESSER.
- TO PREVENT IGNITION OF GROUP A, B, C AND D ATMOSPHERES - SEE INSTRUCTION FOR CHEMICAL COMPATIBILITY

AVERTISSEMENT:

- NE PAS OUVRIR EN PRESENCE D'ATMOSPHERE EXPLOSIVE
- DANGER POTENTIEL CHARGE ÉLECTROSTATIQUE - NETTOYER UNIQUEMENT AVEC UN CHIFFON HUMIDE
- POUR RÉDUIRE LE RISQUE D'INFLAMMATION DES ATMOSPHÈRES DANGEREUSES, LE PREMIERE CONDUIT DE CONDUIT DOIVENT AVOIR UN RACCORD D'ÉTANCHÉITÉ RACCORDÉ À MOINS DE 18 POUCES DE L'ENFERMEMENT. POUR SUBSÉQUENT LES CONDUITES DE CONDUIT LA DISTANCE ENTRE LA SURFACE DE LA MASSE DE REMPLISSAGE AU PLUS PRÈS DE L'ENVELOPPE DOIT ÊTRE AUSSI PETITE QUE CE QUI EST RÉALISABLE MAIS EN AUCUN CAS SUPÉRIEURE À LA PLUS PETITE DES DIMENSIONS CORRESPONDANT À LA TAILLE DU CONDUIT OU À 50 MM.
- POUR PRÉVENIR L'INFLAMMATION DES ATMOSPHÈRES DES GROUPES A, B, C ET D-VOIR L'INSTRUCTION POUR LA COMPATIBILITÉ CHIMIQUE

3) Marking & Rating Information

The D1xH1-A & D1xH1-H Heat Detectors comply with the following standards for hazardous locations:



All models are approved for Fire Alarm System use:

UL 521
CAN/ULC-S530

3.1 Class/Division Ratings for US & Canada

Standards	
UL1203, (Ed 5): Explosion Proof and Dust-Ignition Proof Electrical Equipment for Use in Hazardous (Classified) Locations CSA C22.2 No. 30 (Ed 4): Explosion-proof equipment CSA C22.2 No. 25 (Ed 4): Enclosures for Use in Class II Groups E, F, and G Hazardous Locations	
Class Division Ratings for US (NEC) & Canada (CEC)	
Model No:	Rating
D1xH1-A	Class I Div 1 GR. ABCD T4A Ta -55°C to +80°C Class I Div 1 GR. ABCD T5 Ta -55°C to +75°C Class I Div 1 GR. ABCD T6 Ta -55°C to +60°C Class II Div 1 GR. FG T4A Ta -55°C to +80°C Class III Div 1 Ta -55°C to +80°C
D1xH1-H	Class I Div 1 GR. ABCD T4 Ta -55°C to +125°C Class I Div 1 GR. ABCD T4A Ta -55°C to +115°C Class I Div 1 GR. ABCD T5 Ta -55°C to +95°C Class I Div 1 GR. ABCD T6 Ta -55°C to +80°C Class II Div 1 GR. FG T4 Ta -55°C to +125°C Class II Div 1 GR. FG T5 Ta -55°C to +95°C Class III Div 1 Ta -55°C to +125°C
Class Zone Ratings for US (NEC)	
Model No:	Rating
D1xH1-A	Class I Zone 1 AEx db IIC T4 Gb Ta -55°C to +80°C Class I Zone 1 AEx db IIC T5 Gb Ta -55°C to +70°C Class I Zone 1 AEx db IIC T6 Gb Ta -55°C to +55°C Zone 21 AEx tb IIIC T106°C Db Ta -55°C to +80°C
D1xH1-H	Class I Zone 1 AEx db IIC T4 Gb Ta -55°C to +125°C Class I Zone 1 AEx db IIC T5 Gb Ta -55°C to +90°C Class I Zone 1 AEx db IIC T6 Gb Ta -55°C to +75°C Zone 21 AEx tb IIIC T130°C Db Ta -55°C to +125°C Zone 21 AEx tb IIIC T85°C Db Ta -55°C to +80°C
Class Zone Ratings for Canada (CEC)	
Model No:	Rating
D1xH1-A	Ex db IIC T4 Gb Ta -55°C to +80°C Ex db IIC T5 Gb Ta -55°C to +70°C

	Ex db IIC T6 Gb Ta -55°C to +55°C Ex tb IIIC T106°C Db Ta -55°C to +80°C
D1xH1-H	Ex db IIC T4 Gb Ta -55°C to +125°C Ex db IIC T5 Gb Ta -55°C to +90°C Ex db IIC T6 Gb Ta -55°C to +75°C Ex tb IIIC T85°C Db Ta -55°C to +80°C Ex tb IIIC T130°C Db Ta -55°C to +125°C
Installation must be carried out in compliance with the National Electric Code / Canadian Electric Code	

3.2 ATEX / IECEx & UKEx Ratings

Standards	
EN60079-0:2018/IEC60079-0:2017 (ed.7): Explosive Atmospheres - Equipment General Requirements. EN60079-1:2014/IEC60079-1:2014 (ed.7): Explosive Atmospheres - Equipment Protection by Flameproof Enclosures "d". EN60079-31:2014/IEC60079-31:2022 (ed.3): Explosive Atmospheres - Equipment Dust Ignition Protection by enclosure "t".	
Model No:	Rating
D1xH1-A	Ex db IIC T4 Gb Ta -55°C to +80°C Ex db IIC T5 Gb Ta -55°C to +70°C Ex db IIC T6 Gb Ta -55°C to +55°C Ex tb IIIC T106°C Db Ta -55°C to +80°C
D1xH1-H	Ex db IIC T4 Gb Ta -55°C to +125°C Ex db IIC T5 Gb Ta -55°C to +90°C Ex db IIC T6 Gb Ta -55°C to +75°C Ex tb IIIC T85°C Db Ta -55°C to +80°C Ex tb IIIC T130°C Db Ta -55°C to +125°C
See Product table for electrical ratings of each unit model	

Certificate No. DEMKO 19 ATEX 2009X
IECEx ULD 19.0006X
UL21UKEX2130X

Epsilon x
Equipment Group
and Category:

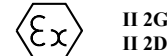

II 2G
II 2D

CE Marking and
Notified Body No.



2813

UKCA Marking and
Notified Body No.



0518

4) Zones, Gas Group, Category and Temperature Classification

The units can be installed in locations with the following conditions:

Area Classification Gas	
Zone 1	Explosive gas air mixture likely to occur in normal operation.
Zone 2	Explosive gas air mixture not likely to occur in normal operation, and if it does, it will only exist for a short time.
Gas Groupings	
Group IIA	Propane
Group IIB	Ethylene
Group IIC	Hydrogen and Acetylene
Temperature Classification for Gas Applications	
T1	450° C
T2	300° C
T3	200° C
T4	135° C
T5	100°C (D1xH1-A for ambients up to 70°C) (D1xH1-H for ambients up to 90°C)
T6	85°C (D1xH1-A for ambients up to 55°C) (D1xH1-H for ambients up to 75°C)
Area Classification Dust	
Zone 21	Explosive dust air mixture likely to occur in normal operation.
Zone 22	Explosive dust air mixture not likely to occur in normal operation, and if it does, it will only exist for a short time.
Dust Groupings	
Group IIIA	Combustible Dusts
Group IIIB	Non-Conductive Dusts
Group IIIC	Conductive Dusts
Equipment Category	
2G, 2D	
Equipment Protection Level	
Gb, Gc, Db, Dc	
Maximum Surface Temperature for Dust Applications	
T106°C (D1xH1-A for ambients up to 80°C) T85°C (D1xH1-H for ambients up to 80°C) T130°C (D1xH1-H for ambients up to 125°C)	
Ambient Temperature Range	
-55°C to +80°C (-67°F to +176°F) D1xH1-A -55°C to +125°C (-67°F to +257°F) D1xH1-H	
IP Rating	
IP66/67 to EN/IEC60529 and IP6X to EN/IEC60079-0, EN/IEC60079-31 4 / 4X / 3R / 13 to UL50E / NEMA250	

5) Special Conditions of Use

Special Condition for safe Use as stated on the Type Examination Certificate DEMKO 19 ATEX 2009X / IECEx ULD 19.0006X & UL21UKEX2130X

Repair of the flameproof threaded joints is not permitted.

The metallic enclosure has a non-conductive coating and may generate an ignition-capable level of electrostatic charges under certain extreme conditions. The user should ensure that the equipment is not installed in a location where it may be subjected to external conditions that might cause a build-up of electrostatic charges on non-conducting surfaces.

Additionally, cleaning of the equipment should be done only with a damp cloth.

Suitable for exposure to Acetone , Ammonium Hydroxide , Diethyl Ether , Ethyl Acetate , Ethylene Dichloride , Furfural , n-hexane , Methyl Ethyl Ketone , Methanol , 2-NitroPropane and Toluene.

6) Flame Path Positions

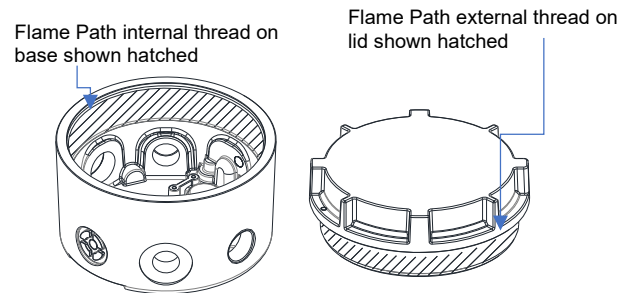

Figure 1: Flame Path.

7) Location and Mounting

The location of the heat detector should enable ease of access for operation and testing. They should only be fixed to services that can carry the weight of the unit.

The D1xH1 Heat Detector can be mounted using one of three methods.

1. The Junction Box can be surface mounted by removing, rotating and reinstalling the stowed mounting lugs. These are suitable for 6mm diameter fixings.

- a. Remove 2 x M5 fasteners per mounting lug
- b. Reverse and rotate lug and reseal onto enclosure
- c. Secure lug using the 2 x M5 Fasteners

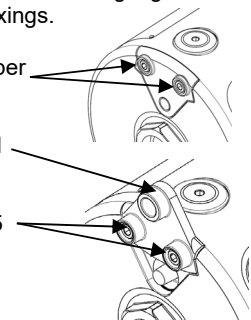

2. Alternatively the Junction Box can be conduit mounted using the 3/4"NPT entry on the base of the unit.
3. Additionally, the Junction Box can be mounted using the ratchet adjustable stainless-steel wall bracket assembly. This is available as an accessory – part code: SP77-0001.

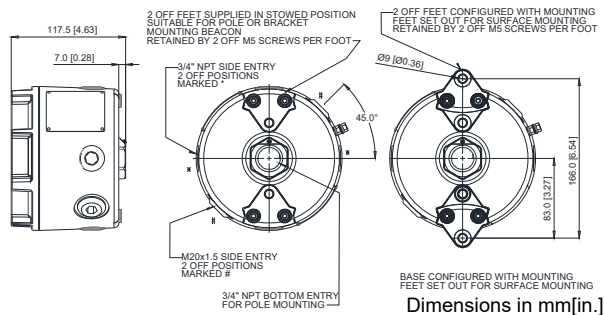

Fig. 1 Fixing Location for Junction Box

The Heat detector element / shell should be mounted with the following consideration :-

The Heat Detector is fitted in an area (normally ceiling) so that:-

- The thermal air path to the shell is not obstructed.
- The heat detectors spacing complies with both system requirements and requirements of the local authority having jurisdiction.
- The element shell is not position sensitive, so can be mounted either vertically or horizontally depending on the application and installation requirements.

8) Access to the Flameproof Enclosure



Warning – High voltage may be present, risk of electric shock. DO NOT open when energised, disconnect power before opening.

To access the enclosures terminals, loosen the M4 grub screw on the heat detector cover. Open the enclosure by turning the heat detector cover counterclockwise and remove the cover.

On completion of the installation the flameproof threaded joint should be inspected to ensure that they are clean and that they have not been damaged during installation. Ensure the O-ring seal is in place and undamaged.

When fitting the cover ensure the thread is engaged correctly. Fully tighten the cover all the way, ensure no gap is visible between the cover and base of the heat detector.

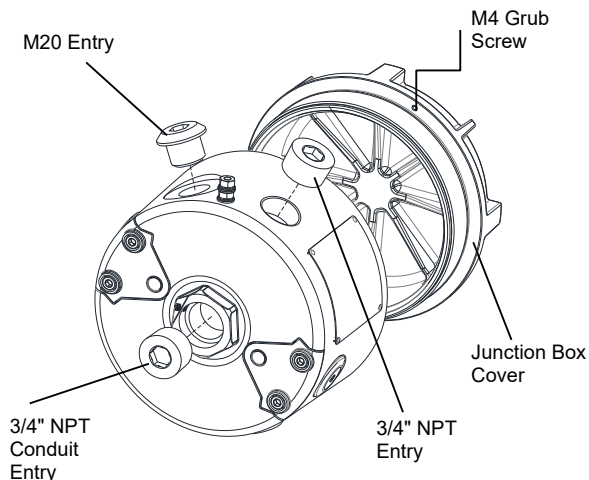

Fig. 2 Accessing the Enclosure.

9) Earthing

The unit has both internal and external earth terminals.

Internal earthing connections should be made to the Internal Earth terminal in the base of the housing using a ring crimp terminal to secure the earth conductor under the earth clamp. The earth conductor should be at least equal in size and rating to the incoming power conductors.

External earthing connections should be made to the M5 earth stud, using a ring crimp terminal to secure the earth conductor to the earth stud. The external earth conductor should be at least 4mm² in size.

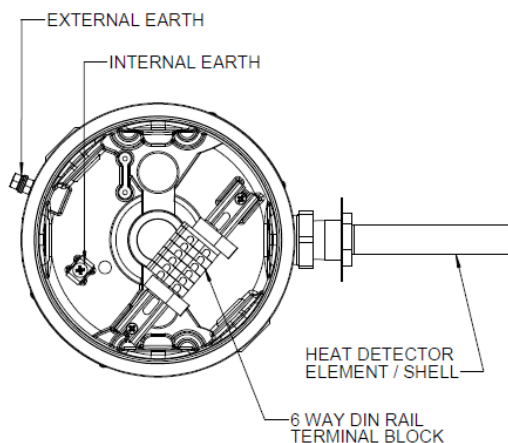

Figure 4: Earth Internal & External

10) Power Supply Selection

Electrical Ratings

See table 1

Max Input Voltage/Current:

125Vac @ 50/60Hz / 5.0A
 125Vdc / 0.5A
 48Vdc / 1A
 24Vdc / 2A

When using EOL or Series monitoring devices voltage should be limited to 48Vdc max for monitoring via a panel.

For D1xH1-A versions when using an LED option C (with no ballast resistor)
 Voltage and Current must be limited as follows 48Vdc max / 20mA

See section 13

Max Power Dissipation:

D1xH1-A 10W
 D1xH1-H 1.25W

11) Selection of Cable. Cable Glands, Blanking Elements & AdaptersATEX/IECEX & UKEx Installations:

The equipment must only be installed by suitably qualified personnel in accordance with the latest issues of the relevant standards:

EN60079-14 / IEC60079-14: Explosive atmospheres - Electrical installations design, selection and erection
 EN60079-10-1 / IEC60079-10-1: Explosive atmospheres - Classification of areas. Explosive gas atmospheres

The installation of the units must also be in accordance with any local codes that may apply and should only be carried out by a competent electrical engineer who has the necessary training.

For high ambient temperatures the cable entry temperature may exceed +70°C or the cable branching point temperature may exceed 80°C and therefore suitable heat resisting cables and cable glands must be used, with a rated service temperature of at least the values stated below:

D1xH1-A:

Max. ambient temperature °C	50	55	60	65	70	75	80
req. Cable / Cable Gland rating: °C	70	75	80	85	90	95	100

D1xH1-H:

Max. ambient temperature °C	65	70	75	80	85	95	105	115	125
req. Cable / Cable Gland rating: °C	70	75	80	85	90	100	110	120	130

The units have 1-off M20 x 1.5 threaded entry and 1-off ¾" NPT x 14 threaded entry, with 1 off ¾" NPT x 14 Pendant entry.

If the installation is made using cable glands, only suitably rated and ATEX / IECEx / UKEx certified cable glands must

be used. They must be suitable for the type of cable being used and also meet the requirements of the current Ex 'db' and Ex 'tb' flameproof and installation standards (tightening torque 10Nm).

If the installation is made using conduit, openings must have a sealing fitting connected as close as practical to the wall of the enclosure, but in no case more than the size of the conduit or 50mm, whichever is the lesser.

Any unused cable entries must be closed with suitably rated and certified blanking plugs that meet ATEX / IECEx / UKEx and the Ex 'db' and Ex 'tb' flameproof and installation standards (tightening torque 10Nm).

NEC / CEC Installations:

The equipment must only be installed by suitably qualified personnel in accordance with the latest issues of the relevant standards:

The installation of the units must also be in accordance with any local codes that may apply and should only be carried out by a competent electrical engineer who has the necessary training.

The equipment must not be installed with any obstruction to the flanged flameproof joint any closer than permitted as per the NEC/CEC.

For high ambient temperatures the cable entry temperature may exceed +60°C or the cable branching point temperature may exceed 60°C and therefore suitable heat resisting cables and cable glands must be used, with a rated service temperature of at least the values stated below:

D1xH1-A:

Max. ambient temperature °C	55	60	65	70	75	80
req. Cable / Cable Gland rating: °C	75	80	85	90	95	100

D1xH1-H:

Max. ambient temperature °C	65	70	75	80	85	95	105	115	125
req. Cable / Cable Gland rating: °C	70	75	80	85	90	100	110	120	130

The units have 1-off M20 x 1.5 threaded entry and 1-off ¾" NPT x 14 threaded entry, with 1 off ¾" NPT x 14 Pendant entry.

Only suitably rated and certified cable glands which must be suitable for the type of cable being used and also meet the requirements of the current Ex 'db' and Ex 'tb' flameproof and NEC/CEC installation standards (tightening torque 10Nm).

When only one cable entry is used the other entries must be closed with suitably rated and certified blanking plugs that meet the requirements of the current Ex 'db' and Ex 'tb' flameproof and NEC/CEC installation standards (tightening torque 10Nm).

If installed is installed in a Class I, Division 2, requires the installation of a flameproof conduit seal or flameproof cable gland at each entry to maintain the Level of Protection flameproof “db”.

All Installations:

If a high IP (Ingress Protection) rating is required then a suitable sealing washer must be fitted under the cable glands or blanking plugs. A minimum ingress protection rating of IP6X must be maintained for installations in explosive dust atmospheres.

The D1xH1 Heat Detector range can be supplied with the following types of adapters:

- M20 to ½” NPT
- M20 to ¾” NPT
- M20 to M25

It is important to note that stopping plugs cannot be fitted onto adapters, only directly onto the M20 entries.

Any other adapters used must be suitably rated and ATEX / IECEx / UKEx or NEC/CEC certified adapters.

12) Cable Connections

Electrical connections are to be made into the DIN-rail mounted inside the heat detector enclosure.

Electrical connections are to be made into the terminals, using solid wire 0.5-4mm² / AWG 20-12 or stranded wire, sizes 0.5-2.5mm² / AWG 24-14, and must be suitable for the terminal block type installed.

If fitting 2-off wires to one terminal way the sum of the 2-off wires must be a maximum cross-sectional area of 2.5mm². Strip wires to 8mm. Wires may also be fitted using ferrules.

Terminal screws need to be tightened down with a tightening torque :-

DIN Rail Terminals: 0.51 Nm / 4.5 Lb-in;

The DIN rail has a 6-way connection and allows for limited wiring of EOL and Series devices by customer, or, full pre-wired configurations if outlined with order to E2S.

For full wiring details see wiring diagrams D255-06-001

For EOL and Series device limitations and configurations see Section 13. Fitting can be requested by E2S at the order stage or added to the correct terminal blocks afterward. All devices must comply with the requirements stipulated in section 13.

When connecting wires to the terminals great care should be taken to dress the wires so that when the cover is inserted into the chamber the wires do not exert excess pressure on the terminal blocks. This is particularly important when using cables with large cross-sectional areas such as 2.5mm².

13) End-of-Line and Series Devices

D1xH1-A models can be fitted with series resistors, end-of-line monitoring resistors, monitoring diodes, zener diodes, also be fitted with specific customer modules and also an

LED option, if voltage is limited to 48Vdc max and limited to a maximum total power consumption no greater than 5W Max.

On D1xH1-A models Ex d LED monitoring module is designated after the model no as either -L to include an LED and power limiting resistor or -C with includes the LED but where the units current must be limited to 20mA.

D1xH1-H Units can be fitted with series / end-of-line monitoring resistors, monitoring diodes and zener diodes, or modules where power consumption is less than an EOL and/or series resistor option, if voltage is limited to 48Vdc max and limited to a maximum total power consumption no greater than 1.25W Max.

Min. device values and current limitations must be observed depending on supply voltage and type of components fitted. If a combination of resistors / diodes / zener diodes or LED is used, values for all components must be observed and lowest current limit for either component becomes overall limit.

Type of component fitted	Supply voltage 24Vdc		Supply voltage 48Vdc	
	value	Max. current (mA)	value	Max. current (mA)
End-of-Line Resistor *See note	Suggested min. 470R/ 2W or min. 2k2/ 0.5W	2000	Suggested min. 2k2/ 2W or min. 8k2/ 0.5W	1000
End-of-Line Diode Type 1N5401	2W	59.13	2W	25.26
Series Resistor *See note	Suggested min. 470R/ 2W or min. 2k2/ 0.5W	2000	Suggested min. 2k2/ 2W or min. 8k2/ 0.5W	1000
Series Diode Type 1N5401	2W	59.13	2W	25.26
Series Zener Diode Type 1N5333B	3.3V	230	3.3V	230
	4.7V	162	4.7V	162
	5.1V	149	5.1V	149
	5.6V	136	5.6V	136
	6.2V	122	6.2V	122
	6.8V	112	6.8V	112
	10V	76	10V	76
	12V	63	12V	63

Table 2 – EOL Devices

An optional Ex d LED monitoring module is designated after the model no. as either,
LED Indicator option [u] = L Then the LED will include an LED and power limiting resistor
or,
LED Indicator option [u] = C Then the LED will include the LED but where the units current must be limited to 20mA.

The optional Ex d LED monitoring module is fitted in the M20 side entry as shown.
For Wiring See D255-06-001

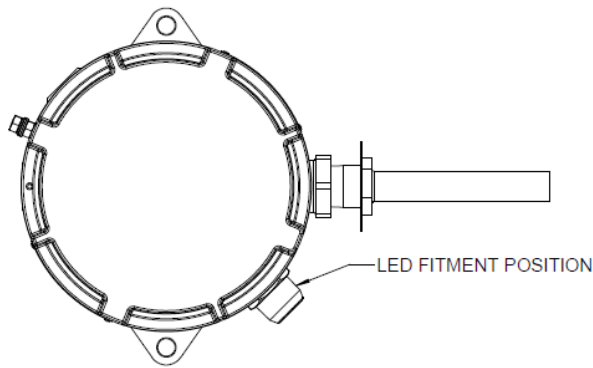

14) Heat Detector Option and Testing

The heat detector is available in the following temperature options.

Unit option code [t]	Setting Temperature	Spacings feet (meters)			RTI (1)	Colour Coding (2)
		UL	Ulc	FM		
01	140°F / 60°C	50 (15)	50 (15)	25 (8)	Fast	Black
02	160°F / 71°C	25 (8)	25 (8)	25 (8)	Fast	Black
03	190°F / 88°C	50 (15)	50 (15)	25 (8)	Fast	White
04	210°F / 99°C	25 (8)	50 (15)	30 (9)	V- Fast	White
05	225°F / 107°C	25 (8)	50 (15)	30 (9)	V- Fast	White
06	275°F / 135°C	25 (8)	50 (15)	30 (9)	V- Fast	Blue
07	325°F / 163°C	50 (15)	50 (15)	30 (9)	V- Fast	Red
08	360°F / 182°C	25 (8)	50 (15)	30 (9)	V- Fast	Red
09	450°F / 232°C	25 (8)	50 (15)	30 (9)	V- Fast	Green
10	500°F / 260°C	50 (15)	50 (15)	30 (9)	V- Fast	Orange
11	600°F / 316°C	N/A	50 (15)	30 (9)	V- Fast	Orange
12	725°F / 385°C	N/A	50 (15)	30 (9)	V- Fast	Orange

Table 3 – Heat Detector Temperature Codes.

- (1) Response Time Index – Heat Detectors sensitivity and speed see EN54-5
 (2) Colour of detector shell marking band.

Functional Test

The functional test of the heat detector is a GO / No Go Test.

- Disconnect the unit from the system.
- Using a heat gun, or similar heat source, apply heat evenly to the complete heat detector element / shell. The heated air temperature must be above the alarm set point temperature of the unit.
- Using an ohm meter, see that the units internal contacts close when the set temperature is reached. Alternatively connect a 24Vdc bulb and power source in series with the detector to see if bulb light on activation.

- Remove the heat immediately after activation to prevent damage to the detector.
- Allow detector to cool to return to it initial open contact state, if the unit fails to return to the original state or activate replace unit.

Note :- The above test must only be performed if the appropriate steps have been taken to prevent unwarranted system activation/deactivation, or unwarranted discharge of an automatic fire extinguishing system. See note below.

HEAT DETECTOR WARNINGS

For an automatic fire extinguishing system, all releasing devices need to be physically disconnected from the release circuits of the control unit prior to any test. Refer to the automatic fire extinguishing systems maintenance manual for the appropriate steps to be taken to physically disconnect the releasing devices prior to testing the detector. Failure to take the necessary steps could result in an accidental discharge that could cause injury and property damage.

- DO NOT overshoot the set point of the unit by more than 100°F (55°C), this could result in a shift of the set point temperature.
- DO NOT contact the sensing shell with a heating device such as a soldering iron or blowtorch as this will damage the unit and cause a shift in the set point temperature.
- Keep the sensing shell of the unit free from Paint, grease and oil, etc. IF build up occurs, do not attempt to remove the buildup, Replace the unit.
- Detectors mounted in an area of physical abuse or damage must be protected without obstructing the thermal airpaths to the unit.
- Do not install the unit where the shell would be physically damaged by sand, grain, rock, etc.
- Any detector that has been involved in a fire or damaged must be replaced.
- Do not re-install or tighten detector element in junction box.

Note that any of the above could change the factory temperature settings, which may result in property damage and/or personal injury or death. It is possible for a unit to have been abused or damaged and not display any outwards indication of the damage. All units should be tested periodically in accordance with National Fire Protection Association Requirements (72e) or the Authority having local jurisdiction.

15) Maintenance, Overhaul & Repair

Maintenance, repair and overhaul of the equipment should only be carried out by suitably qualified personnel in accordance with the current relevant standards:

For ATEX / IECEx / UKEx

EN60079-19/IEC60079-19 Explosive atmospheres - Equipment repair, overhaul and reclamation

EN60079-17/IEC60079-17 Explosive atmospheres - Electrical installations inspection and maintenance

Units must not be opened while an explosive atmosphere is present.

Units must not be opened while an explosive atmosphere is present.

If opening the unit during maintenance operations a clean environment must be maintained and any dust layer removed prior to opening the unit.

Repair of the flameproof threaded joints is not permitted.

Potential electrostatic charging hazard - Clean only with a damp cloth.

For NEC / CEC

- UL 60079-19 Explosive atmospheres – Equipment repair, overhaul and reclamation
- UL 60079-17 Explosive atmospheres – Electrical installations inspections and maintenance

Potential Electrostatic charging hazard – clean only with a damp cloth.

Units must not be opened while an explosive atmosphere is present.

To avoid a possible ELECTROSTATIC CHARGE the unit must only be cleaned with a damp cloth.

Units must not be opened while an explosive atmosphere is present.

Heat Detector for all installations

As part of the recommended maintenance procedure, perform a visual inspection of the D1xH1 Heat Detector in accordance with NFPA 72 guidelines, ensuring:-

- The heat detector element / shell is free of dents, dings or build up of foreign matter of any kind.
- If the shell is dented or shows signs of any physical damage, replace the unit immediately.
- If a build up of dust has accumulated on the unit, clean the unit with a clean damp cloth.
- If the detector element / shell has been painted, replace the unit. Note that some units are factory coated (set temperature identification band). Do not confuse these with units that were painted by the owners.

HEAT DETECTOR DEVICES

SHEET 1

PRODUCTS: D1xH1 ; STExH1	Diagram	Sheet
	Standard Switch Wiring Configurations	1
	LED Indicator Wiring Configurations	2

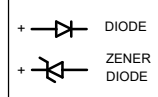

Module Device Codes		
	EOL	Series
Resistor	ExxxR	SxxxR
Diode	ED1	SD1
Zener Diode	ExxxZ	SxxxZ
LED	N/A	L or C

ISSUE	MOD No.	REASON - INITIAL - DATE
1		INTRODUCTION RNP 10-05-2024

HEAT DETECTOR	CONFIG. A1-1	HEAT DETECTOR WITH EOL DEVICE	CONFIG. A1-2	HEAT DETECTOR WITH SERIES DEVICES	CONFIG. A1-3	HEAT DETECTOR WITH EOL & SERIES DEVICES	CONFIG. A1-4	HEAT DETECTOR WITH EOL & ALT. SERIES DEVICES	CONFIG. A1-5
---------------	--------------	-------------------------------	--------------	-----------------------------------	--------------	---	--------------	--	--------------

PRODUCT VERSION [v]	[A]	Ex d	PRODUCT VERSION [v]	[A]	Ex d	PRODUCT VERSION [v]	[A]	Ex d	PRODUCT VERSION [v]	[A]	Ex d
PRODUCT OPTION [o]	[1]	Default	PRODUCT OPTION [o]	[1]	Default	PRODUCT OPTION [o]	[1]	Default	PRODUCT OPTION [o]	[W]	Alt. EOL Pos'n.
LED INDICATOR [u]	[N]	NO LED	LED INDICATOR [u]	[N]	NO LED	LED INDICATOR [u]	[N]	NO LED	LED INDICATOR [u]	[N]	NO LED
SERIES MODULE [e]	[Exxxx]	EOL	SERIES MODULE [e]	[Exxxx]	EOL	SERIES MODULE [s]	[Sxxxx]	Series	MODULE [e][s]	[Exxxx]	EOL + Series

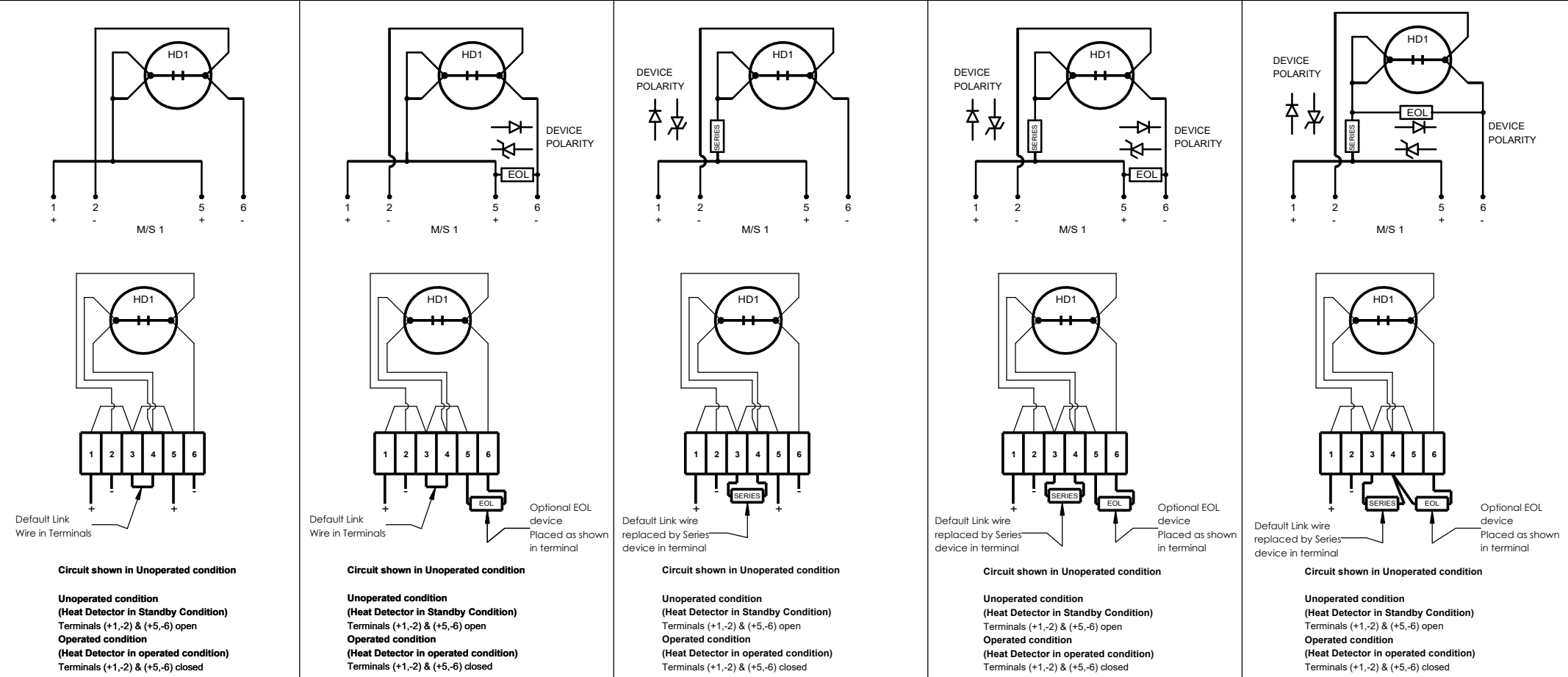

DRAWING TO BS8888:2000 GEOMETRIC TOLERANCES TO ISO1101:1983 LINEAR DIMENSIONAL TOLS ANGULAR DIMENSIONAL TOLS	DRAWN	DATE	SURFACE FINISH	WEIGHT (Kg)	THIS DRAWING AND ANY INFORMATION OR DESCRIPTIVE MATTER THEREIN IS COMMUNICATED IN CONFIDENCE AND IS THE COPYRIGHT PROPERTY OF EUROPEAN SAFETY SYSTEMS LTD. NEITHER THE WHOLE OR ANY EXTRACT MAY BE DISCLOSED, LOANED, COPIED OR USED FOR MANUFACTURING OR TENDERING PURPOSES WITHOUT THEIR WRITTEN CONSENT.	 EUROPEAN SAFETY SYSTEMS LTD IMPRESS HOUSE MANSELL ROAD ACTON LONDON W3 7QH WWW.E2S.COM	ALL DIMENSIONS IN MM IF IN DOUBT, ASK - DO NOT SCALE			 A3
	CHECKED	DATE					MATERIAL	TITLE		
	STANDARDS D1xH1-A ; D1xH1-H STExH1-A ; STExH1-H	R.N.POTTS	10-05-2024	B.ISARD			10-05-2024	ALTERNATIVE MATERIAL	TITLE D1xH1-A & -H ; STExH1-A & -H Ex d HEAT DETECTOR WIRING / CIRCUIT OPERATION DIAGRAM	SCALE
	R.N.POTTS	10-05-2024			EUROPEAN SAFETY SYSTEMS LTD. AS PER LATEST DATE OF ISSUE SHOWN ABOVE		NTS	1 OF 2	D255-06-001	

HEAT DETECTOR WITH LED DEVICES

SHEET 2

Module Device Codes

	EOL	Series
Resistor	ExxxR	SxxxR
Diode	ED1	SD1
Zener Diode	ExxxZ	SxxxZ
LED	N/A	L or C

ISSUE	MOD No.	REASON - INITIAL - DATE
1		INTRODUCTION RNP 10-05-2024

Notes:

- LED option 'L': LED contains the 1.5K Ohm series current-limiting resistor RL1.
LED option 'C': LED does not contain a current-limiting resistor. System current must be <20mA.
All schematic diagrams below show option 'L' LED - remove RL1 for 'C' LED option.

HEAT DETECTOR WITH LED ONLY	CONFIG. A2-1	HEAT DETECTOR WITH LED & EOL DEVICE	CONFIG. A2-2	HEAT DETECTOR WITH LED EOL & SERIES DEVICES	CONFIG. A2-3	HEAT DETECTOR WITH LED, EOL & ALT. SERIES DEVICE	CONFIG. A2-4
-----------------------------	--------------	-------------------------------------	--------------	---	--------------	--	--------------

PRODUCT VERSION [v] [A] PRODUCT OPTION [o] [1] LED INDICATOR [u] [L]	Ex d Default LED with RL1	PRODUCT VERSION [v] [A] PRODUCT OPTION [o] [1] LED INDICATOR [u] [L] MODULE [E] [Exxxx]	Ex d Default LED with RL1 EOL Device	PRODUCT VERSION [v] [A] PRODUCT OPTION [o] [1] LED INDICATOR [u] [L] MODULES [e] [s] [Exxxx] [Sxxxx]	Ex d Default LED with RL1 EOL + Series	PRODUCT VERSION [v] [A] PRODUCT OPTION [o] [W] LED INDICATOR [u] [L] MODULE [e] [s] [Exxxx] [Sxxxx]	Ex d Alt. EOL Pos'n. LED with RL1 EOL + Series
--	---------------------------------	--	---	---	---	--	---

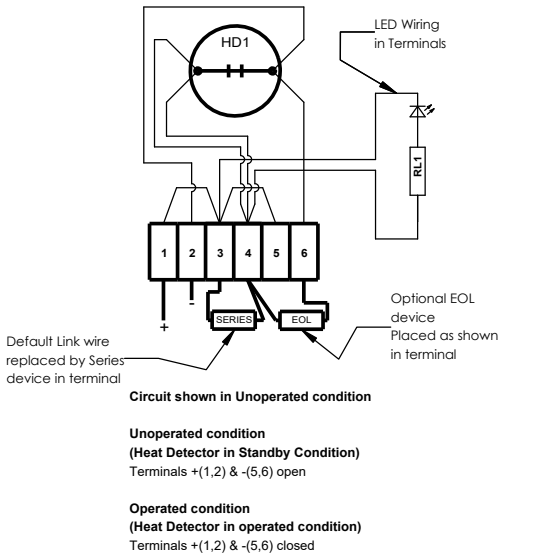
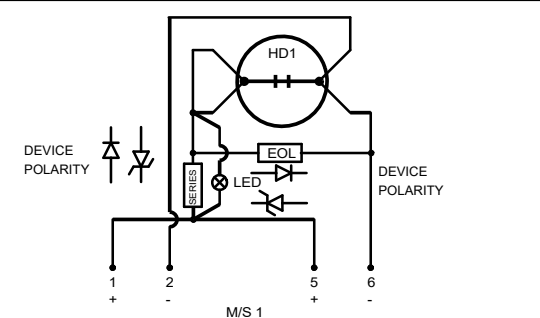
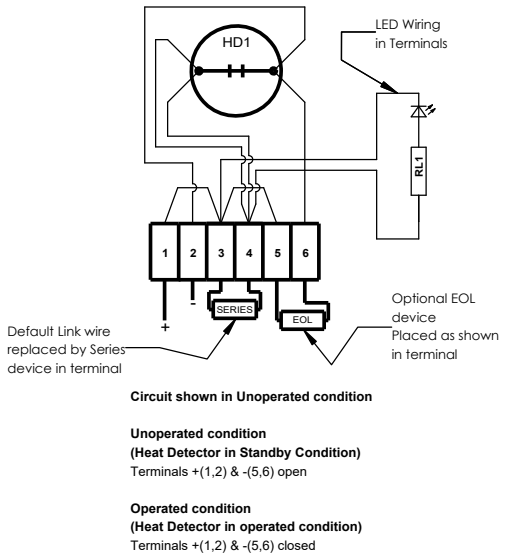
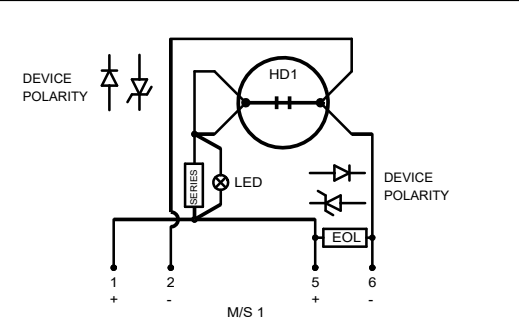
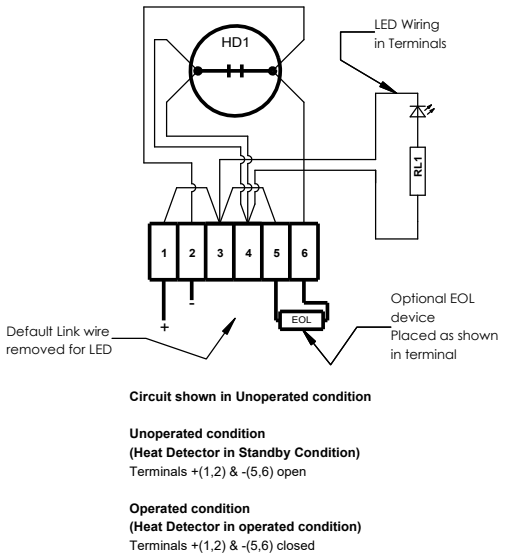
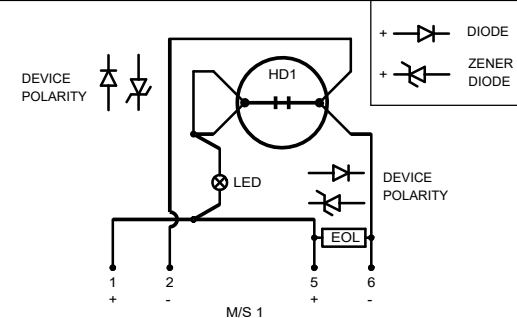
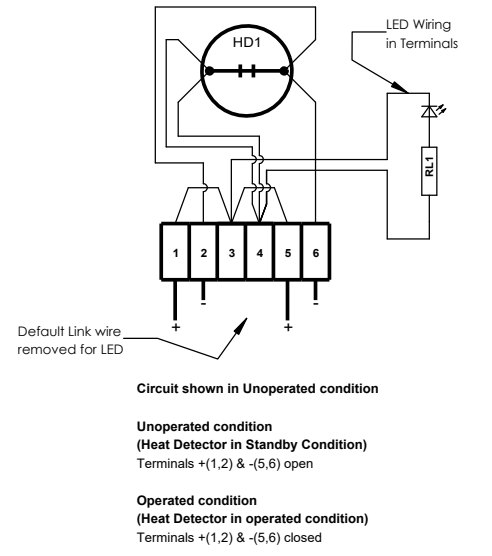
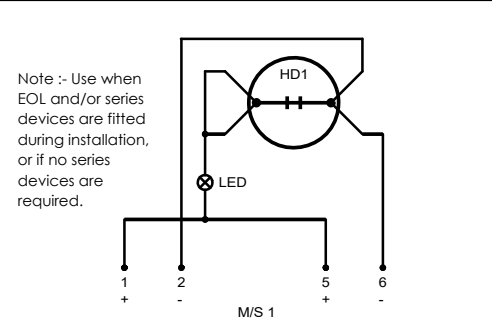

DRAWING TO BS8888:2000
GEOMETRIC TOLERANCES TO ISO1101:1983
LINEAR DIMENSIONAL TOLS
ANGULAR DIMENSIONAL TOLS

STANDARDS
D1xH1-A ; D1xH1-H
STExH1-A ; STExH1-H

DRAWN	DATE
R.N.POTTS	10-05-2024
CHECKED	DATE
B.ISARD	10-05-2024
APPROVED	DATE
R.N.POTTS	10-05-2024

SURFACE FINISH	WEIGHT (Kg)
MATERIAL	
ALTERNATIVE MATERIAL	

THIS DRAWING AND ANY INFORMATION OR DESCRIPTIVE MATTER THEREIN IS COMMUNICATED IN CONFIDENCE AND IS THE COPYRIGHT PROPERTY OF EUROPEAN SAFETY SYSTEMS LTD. NEITHER THE WHOLE OR ANY EXTRACT MAY BE DISCLOSED, LOANED, COPIED OR USED FOR MANUFACTURING OR TENDERING PURPOSES WITHOUT THEIR WRITTEN CONSENT.

EUROPEAN SAFETY SYSTEMS LTD.
AS PER LATEST DATE OF ISSUE SHOWN ABOVE

e2s warning signals
EUROPEAN SAFETY SYSTEMS LTD
IMPRESS HOUSE
MANSELL ROAD
ACTON
LONDON W3 7QH
WWW.E2S.COM

ALL DIMENSIONS IN MM IF IN DOUBT, ASK - DO NOT SCALE			A3
TITLE D1xH1-A & -H ; STExH1-A & -H Ex d HEAT DETECTOR WIRING / CIRCUIT OPERATION DIAGRAM			
SCALE	SHEET	DRAWING NUMBER	
NTS	2 OF 2	D255-06-001	

EU Declaration of Conformity



Manufacturer: European Safety Systems Ltd.
Impress House, Mansell Road, Acton
London, W3 7QH
United Kingdom

Authorised Representative: E2S Warnsignaltechnik UG
Charlottenstrasse 45-51
72764 Reutlingen
Germany

Equipment Type: D1xH1-A, D1xH1-H

Directive 2014/34/EU: Equipment and Protective Systems for use in Potentially Explosive Atmospheres (ATEX)

Notified Body for EU type Examination (Module B):	UL International Demko A/S Notified Body No.: 0539 Borupvang 5A, 2750 Ballerup, Denmark
EU-type Examination Certificate (Module B):	DEMKO 19 ATEX 2009X
Notified Body for Quality Assurance Notification / Conformity to EU-type based on quality assurance of the production process (Module D):	Sira Certification Service Notified Body No.: 2813 Unit 6, Hawarden Industrial Park, Hawarden, Deeside, CH5 3US, UK
Quality Assurance Notification (Module D):	SIRA 05 ATEX M342
Provisions fulfilled by the equipment:	II 2G Ex db IIC T6...T4 Gb II 2D Ex tb IIIC T85 °C...130 °C Db
Standards applied:	EN IEC 60079-0:2018 EN 60079-1:2014 EN60079-31:2014

Directive 2014/30/EU: Electromagnetic Compatibility Directive (EMC)

Standards applied:	EN 61000-6-1:2007 EN 61000-6-2:2005 EN 61000-6-3:2007 / A1:2011 / AC: 2012 EN 61000-6-4:2007 / A1: 2011
--------------------	--

Directive 2014/35/EU: Low Voltage Directive (LVD)

Standards applied:	EN 60947-1:2007 + A2:2014
--------------------	---------------------------

Directive 2011/65/EU: Restriction of the use of certain hazardous substances in electrical and electronic equipment (RoHS)

The product and all the components contained within it are in accordance with the restriction of the use of hazardous substances in electrical and electronic equipment, including amendment by Directive 2015/863/EU.

Regulation (EC) 1907/2006: Registration, Evaluation, Authorisation and Restriction of Chemicals (REACH)

The product and all the components contained within it are free from substances of very high concern.

Other Standards and Regulations

EN 60529:1992+A2:2013 - Degrees of protection provided by enclosures (IP code) – enclosure rated IP66/7

On behalf of European Safety Systems Ltd., I declare that, on the date the equipment accompanied by this declaration is placed on the market, the equipment conforms with all technical and regulatory requirements of the above listed directives, regulations and standards.

This Declaration is issued under the sole responsibility of the manufacturer.

A blue ink signature of Desmond Gayler, written in a cursive style.

Desmond Gayler
Quality Assurance Manager

Document No.:	DC-120_Issue_A
Date and Place of Issue:	London, 07/06/2024

Manufacturer: European Safety Systems Ltd.
Impress House, Mansell Road, Acton
London, W3 7QH
United Kingdom

Equipment Type: D1xH1-A, D1xH1-H

Directive UKSI 2016:1107 (as amended by UKSI 2019:696) – Schedule 3A, Part 1 : Product or Protective System Intended for use in Potentially Explosive Atmospheres (UKCA)

Notified Body for UK type Examination (Module B):	UL International (UK) Ltd Notified Body No.: 0843 Unit 1-3 Horizon Kingsland Business Park, Wade Road, Basingstoke, Hampshire RG24 8AH UK
UK-type Examination Certificate (Module B):	UL21UKEX2130X
Notified Body for Quality Assurance Notification / Conformity to EU-type based on quality assurance of the production process (Module D):	Sira Certification Service Notified Body No.: 0518 Rake Lane, Eccleston, Chester CH4 9JN, UK
Quality Assurance Notification (Module D):	CSAE 22UKQAN0046
Provisions fulfilled by the equipment:	II 2G Ex db IIC T6...T4 Gb II 2D Ex tb IIIC T85°C...130°C Db
Standards applied:	EN IEC 60079-0:2018 EN 60079-1:2014 EN60079-31:2014

Directive 2014/30/EU: Electromagnetic Compatibility Directive (EMC)

Standards applied:	EN 61000-6-1:2007 EN 61000-6-2:2005 EN 61000-6-3:2007 / A1:2011 / AC: 2012 EN 61000-6-4:2007 / A1: 2011
--------------------	--

Directive 2014/35/EU: Low Voltage Directive (LVD)

Standards applied:	EN 60947-1:2007 + A2:2014
--------------------	---------------------------

Directive 2011/65/EU: Restriction of the use of certain hazardous substances in electrical and electronic equipment (RoHS)

The product and all the components contained within it are in accordance with the restriction of the use of hazardous substances in electrical and electronic equipment, including amendment by Directive 2015/863/EU.

Regulation (EC) 1907/2006: Registration, Evaluation, Authorisation and Restriction of Chemicals (REACH)

The product and all the components contained within it are free from substances of very high concern.

Other Standards and Regulations

EN 60529:1992+A2:2013 - Degrees of protection provided by enclosures (IP code) – enclosure rated IP66/7

On behalf of European Safety Systems Ltd., I declare that, on the date the equipment accompanied by this declaration is placed on the market, the equipment conforms with all technical and regulatory requirements of the above listed directives, regulations and standards.

This Declaration is issued under the sole responsibility of the manufacturer.



Desmond Gayler
Quality Assurance Manager

Document No.: DC-128_Issue_A
Date and Place of Issue: London, 07/06/2024