

INSTRUCTION MANUAL

STExS1

Alarm Horn Sounder

For use in Flammable Gas and Dust Atmospheres

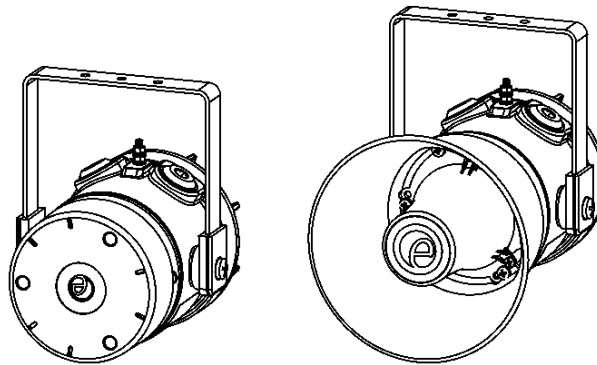

STExS1R

STExS1F

1) Product Table

Standards	Model	Nominal Input Voltage	Nominal Input Current	Voltage Range	Max. Current	Sound Pressure Level dB(A)		
						Max*	Nom [†]	
ATEX / IECEx / UKEx / NEC / CEC	STExS1RDC024	12Vdc	221mA	11.5-54Vdc	221mA	110	105	
		24Vdc	185mA					
		48Vdc	115mA					
	STExS1RAC230	115Vac	73mA	100-240Vac 50/60Hz	80mA	110	105	
		230Vac	48mA					
	STExS1FDC024		12Vdc	221mA	11.5-54Vdc	221mA	115	110
			24Vdc	185mA				
			48Vdc	115mA				
	STExS1FAC230		115Vac	73mA	100-240Vac 50/60Hz	80mA	115	110
			230Vac	48mA				

*Max = Tone 4
†Nom. = Tone 44

The table shows the input current taken by the various sounders.
The current levels shown above are for the 440Hz Continuous tone @ nominal input voltage.
Nominal current at nominal voltage.
Max rated current at worst case supply voltage.

Table 1: Electrical Ratings.

Ensure the system power supply is capable of providing the maximum current required for all beacons. Review associated cable size, length and quantity of beacons on each circuit.

2) Warnings



- DO NOT OPEN WHEN AN EXPLOSIVE ATMOSPHERE IS PRESENT.
- POTENTIAL ELECTROSTATIC CHARGING HAZARD.
- ALL ENTRIES M20 X 1.5MM.
- USE SUITABLE RATED CABLES AND CABLE GLANDS IF TEMPERATURE EXCEEDS AS PER STANDARDS INDICATIONS BELOW.

FOR ATEX / IECEX & UKEx STANDARDS:

70°C AT ENTRY OR 80°C AT BRANCHING POINT.

FOR NEC / CEC STANDARDS:

60°C AT ENTRY OR 60°C AT BRANCHING POINT.

3) Marking & Rating Information

All units have a rating label, which carries the following important information.

Products may have further approvals, see E2S website for further details.

3.1. ATEX / IECEX & UKEx Ratings

Standards	
EN IEC 60079-0:2018 / IEC60079-0:2017 (Ed 7): Explosive Atmospheres - Equipment. General requirements	
EN60079-1:2014 / IEC60079-1:2014 (Ed 7): Explosive Atmospheres - Equipment protection by flameproof enclosures "d"	
EN 60079-31:2014 / IEC 60079-31:2013 (Ed 2): Explosive Atmospheres - Equipment dust ignition protection by enclosure "t"	
Model No:	Rating
STExS1:	Ex db IIC T6 Gb Ta -50°C to +65°C
DC024	Ex db IIC T5 Gb Ta -50°C to +70°C
AC230	Ex db IIIC T82°C Db Ta -50°C to +70°C

Certificate No. DEMKO 16 ATEX 1466X
IECEX ULD 16.0017X
UL21UKEX2019X

Epsilon x
Equipment Group
and Category:



II 2G
II 2D

CE Marking and
Notified Body No.



2813

UKCA Marking and
Notified Body No.



0518

3.2. NEC / CEC Ratings



Gas Class I

All models are approved for use as Alarm Horns also comply with the following standards for signaling equipment:

UL464A & CSA C22.2 NO. 205-17

NEC Class / Zone Ratings US Codes

Standards	
UL 60079-0 (Ed. 7) 04/15/2020 Explosive Atmospheres - part 0: Equipment - General Requirements	
UL 60079-1 (Ed. 7) 2015 Explosive Atmospheres - Part 1: Equipment Protection by Flameproof Enclosures 'd'	
Ratings	
STExS1:	Class 1 Zone 1 AEx db IIC T5 Gb Ta -50°C to +70°C
DC024	Class 1 Zone 1 AEx db IIC T6 Gb Ta -50°C to +65°C
AC230	

Installation must be carried out in compliance with the National Electrical Code.

CEC Class / Zone Ratings Canada

Standards	
CAN/CSA C22.2 No. 60079-0 (Ed. 4) 02/2019 Explosive Atmospheres - Part 0: Equipment - General Requirements	
CAN/CSA C22.2 No. 60079-1 (Ed. 3) 2016 Electrical Apparatus for Explosive Gas Atmospheres - Part 1: Flameproof Enclosures 'd'	
Rating	
STExS1:	Ex db IIC T5 Gb Ta -50°C to +70°C
DC024	Ex db IIC T6 Gb Ta -50°C to +65°C
AC230	

Installation must be carried out in compliance with the Canadian Electric Code.

NEC & CEC Class / Division Ratings for US / Canada, USL CNL

Standards	
UL464A (Ed. 1) 2017 Standard for Audible Signal Appliances for General Signalling Use	
CSA C22.2 No. 205-17 (Ed. 3) 2017 Signal Equipment	
Rating	
STExS1:	Class I Div 2 Group ABCD T5 Ta -50°C to +70°C
DC024	Class I Div 2 Group ABCD T6 Ta -50°C to +65°C
AC230	

Installation must be carried out in compliance with the National Electric Code / Canadian Electric Code.

3.3 DNV GL Type Approval

STExS1RDC024 & STExS1FDC024 units have been tested and approved for the installation on ships in the following locations:

- Temperature:** Class A,B,C & D (all locations including open decks and masts)
Humidity: Class A & B (all locations)
Vibration: Class A (all locations except installation on machinery such as combustion engines, compressors, pumps, including piping on such machinery)
EMC: Class A & B (all locations including open decks and bridge)
Enclosure: Class A, B & C – IP56 (all locations expect submerged applications and bilges)

3.4 Type Approval Standards

STExS1RDC024 & STExS1FDC024 carry Type Approval by DNV GL to the following guidelines:

Class Guideline DNVGL-CG-0339:
 Environmental test specification for electrical, electronic and programmable equipment and systems

4 Zones, Gas Group, Category and Temperature Classification

The units can be installed in locations with the following conditions:

Area Classification	
Zone 1	Explosive gas air mixture likely to occur in normal operation.
Zone 2	Explosive gas air mixture not likely to occur in normal operation, and if it does, it will only exist for a short time.
Zone 21 (ATEX / IECEx & UKEx only)	Explosive dust air mixture likely to occur in normal operation.
Zone 22 (ATEX / IECEx & UKEx only)	Explosive dust air mixture not likely to occur in normal operation, and if it does, it will only exist for a short time.
Gas Groupings	
Group IIA	Propane
Group IIB	Ethylene
Group IIC	Hydrogen and Acetylene
Temperature Classification for Gas Applications	
T1	450° C
T2	300° C
T3	200° C
T4	135° C
T5	100° C
T6	85° C (STExS1 up to 65° C ambient)
Dust Groupings (ATEX / IECEx & UKEx only)	
Group IIIA	Combustible Flyings
Group IIIB	Non-conductive Dust
Group IIIC	Conductive Dust

Maximum Surface Temperature for Dust Applications (ATEX / IECEx & UKEx only)	
STExS1	82° C
Equipment Category	
2G / 2D	
Equipment Level Protection	
Gb, Gc, Db, Dc	
Ambient Temperature Range	
-50° C to +70° C	
IP Rating	
IP6X to EN/IEC60079-0 IP66 to EN60529	

5 Special Conditions for Safe Use

Repair of the flameproof threaded joints and cemented joints is not permitted.

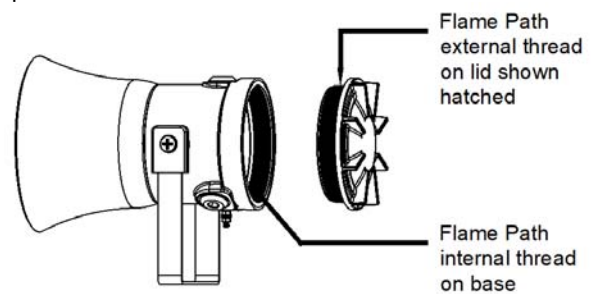

Figure 1: Flame Path

The plastic horn is not anti-static, and the metallic enclosure has a non-conductive coating. These may generate an ignition-capable level of electrostatic charges under certain extreme conditions. The user should ensure that the equipment is not installed in a location where it may be subjected to external conditions that might cause a build-up of electrostatic charges on non-conducting surfaces.

NEC / CEC Requirements Only

All entries must be fitted with a suitable seal at the interface with enclosure.

6 Product Mounting and Access

6.1 Location and Mounting

The sounder should be secured to any flat surface using the three 7mm fixing holes (see figure 2). The angle can then be adjusted as required but the mounting restrictions must be observed (see outline drawings for details, D199-05-001 for STExS1F and D199-05-021 for STExS1R). This can be achieved by loosening the two large bracket screws in the side of the unit, which allow adjustments in steps of 18°.

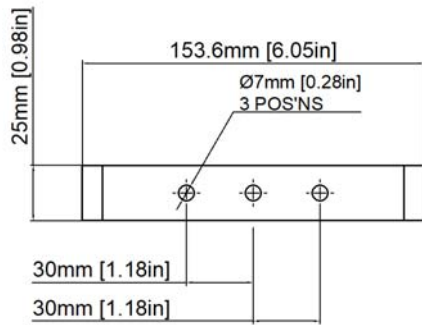

Figure 2: Fixing Location for STEx[S1R/S1F] Sounder.

On completion of the installation the two large bracket adjustment screws on the side of the unit must be fully tightened to ensure that the unit cannot move in service.

The enclosure provides IP66 protection and is suitable for installation in exterior locations providing it is positioned so that water cannot collect in the horn, and the cable entry is sealed.

6.2 Access to the Flameproof Enclosure



Warning – Hot surfaces. External surfaces and internal components may be hot after operation, take care when handling the equipment.

In order to connect the electrical supply cables to the sounder it is necessary to remove the flameproof cover to gain access to the flameproof chamber. To access the Ex d chamber, loosen the M4 grub screw on the sounder cover. Open the enclosure by turning the sounder cover counterclockwise and remove the cover, taking extreme care not to damage the flameproof threads in the process (See figure 3).

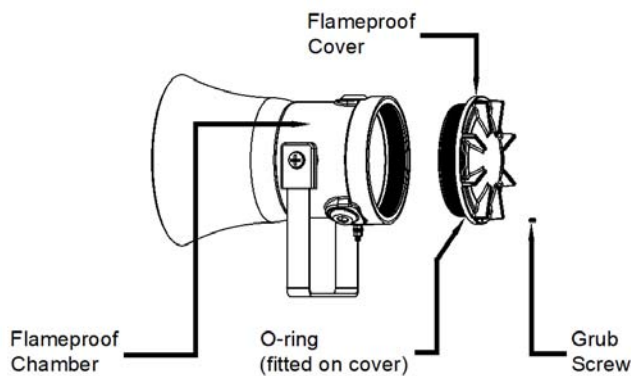

Figure 3: Accessing the Explosion Proof Enclosure.

On completion of the installation, the flameproof threaded joint should be inspected to ensure that they are clean and that they have not been damaged during installation.

Ensure that the 'O' ring seal is in place and undamaged.

When fitting the flameproof cover ensure the thread is engaged correctly. Fully tighten the cover all the way, ensure no gap is visible between the cover and base of the sounder enclosure. Tighten the M4 grub screw.

7 Installation Requirements

7.1 Installation Standards Compliance



Warning – High voltage may be present, risk of electric shock. DO NOT open when energised, disconnect power before opening.

The sounder must only be installed by suitably qualified personnel in accordance with the latest issues of the relevant standards.

ATEX / IECEx & UKEx Installation Standards

EN60079-14 / IEC60079-14: Explosive atmospheres - Electrical installations design, selection and erection.

EN60079-10-1 / IEC60079-10-1: Explosive atmospheres - Classification of areas. Explosive gas atmospheres.

EN60079-10-2 / IEC60079-10-2: Explosive atmospheres - Classification of areas. Explosive dust atmospheres.

The installation of the units must also be in accordance with any local codes that may apply and should only be carried out by a competent electrical engineer who has the necessary training.

NEC / CEC Installation Standards

Cautions



Attention: Installation must be carried out by an electrician in compliance with the National Electrical Code, NFPA 70 or CSA 22.1 Canadian Electrical Code, Part I, Safety Standard for Electrical Installations, Section 32. / L'installation doit exclusivement être réalisée par du personnel qualifié, conformément au code national d'électricité américain, NFPA 70 ou CSA 22.1 Code canadien de l'électricité, première partie, norme de sécurité relative aux installations électriques, Section 32.



Attention: Disconnect from power source before installation or service to prevent electric shock / Débranchez-le de la source d'alimentation avant l'installation ou l'entretien pour éviter tout choc électrique.

The installation of the units must also be in accordance with the NEC / CEC and any local regulations and should only be carried out by a competent electrical engineer who has the necessary training.

7.2 Cable Selection and Connections

When selecting the cable size, consideration must be given to the input current that each unit draws (see table 1), the number of sounders on the line and the length of the cable runs. The cable size selected must have the necessary capacity to provide the input current to all of the sounders connected to the line.

Electrical connections are to be made into the terminal blocks on the PCBA located in the flameproof enclosure using solid wire 0.5-4mm² / AWG 20-12 or stranded wire, sizes 0.5-2.5mm² / AWG 24-14. Wire insulation needs to be stripped 8mm. Wires may be fitted securely with crimped ferrules.

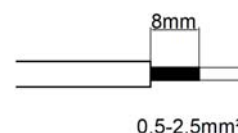

Figure 4: Wire Preparation.

Terminal screws need to be tightened down with a tightening torque of 0.45 Nm / 5 Lb-in. An 8-way terminal block is provided on the AC Sounder, and a 6-way terminal block is provided on the DC Sounder.

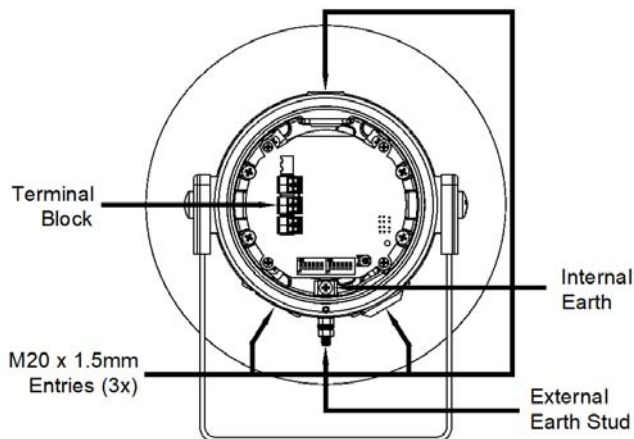

Figure 5: STExS1 Entries and Terminal Block Location.

When connecting wires to the terminals great care should be taken to dress the wires so that when the cover is inserted into the chamber the wires do not exert excess pressure on the terminal blocks. This is particularly important when using cables with large cross-sectional areas such as 2.5mm².

Earthing

Please note that for AC supply voltage product versions the Earth terminal on the PCBA does not provide an earth connection to the product enclosure. The enclosure must be independently earthed using either the external or internal earth fixing point, (see fig 5 and notes below).

Both AC and DC sounder units must be connected to an earth according to EN/IEC 60079/14. The units are provided with internal and external earth terminals which are both located on the terminal chamber section of the unit (see figure 5).

External earthing connections should be made to the M5 earth stud, using a ring crimp terminal to secure the earth conductor to the earth stud between the two M5 stainless steel flat washers, then reassemble the M5 spring washer and tighten the M5 nut to ensure that the cable lug is secured against loosening and twisting. The external earth conductor should be at least 4mm² in size.

ATEX / IECEx & UKEx Requirements Only

Internal earthing connections should be made to the Internal Earth terminal in the base of the housing using a ring crimp terminal to secure the earth conductor under the earth clamp. The earth conductor should be at least equal in size and rating to the incoming power conductors.

NEC / CEC Requirements Only

Internal earthing connections should be made to the Internal Earth terminal in the base of the housing using a ring crimp terminal to secure the earth conductor under the earth clamp. The earth conductor should be at least equal in size and rating to the incoming power conductors but at least a minimum of 0.82mm² / 18AWG in size.

7.3 Cable Glands, Blanking Elements & Adapters

Follow the minimum temperature ratings of cables and cable glands according to the approvals applied.

ATEX / IECEx & UKEx Requirements Only

For high ambient temperatures the cable entry temperature may exceed 70°C or the cable branching point temperature may exceed 80°C and therefore suitable heat resisting cables and cable glands must be used, with a rated service temperature at least as stated below:

Model	Ambient Temperature (°C)			
	55	60	65	70
DC024	75	80	85	90
AC230		75	80	85

Table 2: ATEX / IECEx & UKEx Min. Ratings of Cables & Cable Glands.

NEC / CEC Requirements Only

For high ambient temperatures the cable entry temperature may exceed 60°C or the cable branching point temperature may exceed 60°C and therefore suitable heat resisting cables and cable glands must be used, with a rated service temperature at least as stated below:

Model	Ambient Temperature (°C)						
	40	45	50	55	60	65	70
DC024	60	65	70	75	80	85	90
AC230		60	65	70	75	80	85

Table 3: NEC / CEC Min. Ratings of Cables & Cable Glands.

Cable Glands & Blanking Plugs

Appropriate cable glands to be customer supplied.

ATEX / IECEx & UKEx Requirements Only

The cable entries have an M20 x 1.5 – 6H entry thread. Only suitably rated and ATEX / IECEx & UKEx certified cable glands must be used. They must be suitable for the type of cable being used and also meet the requirements of the current installation standards EN 60079-14 / IEC60079-14.

If the installation is made using conduit, openings must have a sealing fitting connected as close as practical to the wall of the enclosure, but in no case more than the size of the conduit or 50mm, whichever is the lesser.

Any unused cable entries must be closed with suitably rated and ATEX / IECEx & UKEx certified blanking plugs.

NEC / CEC Requirements Only

The cable entries have an M20 x 1.5 – 6H entry thread. Only suitably rated and certified cable glands must be used. They must be suitable for the type of cable being used and also meet the requirements of the current installation standards for NEC / CEC.

For use in Class I Division II locations, in order to maintain the db type protection, flameproof conduit seals and/or cable glands must be used.

Any unused cable entries must be closed with suitably rated and certified blanking plugs.

Ingress Protection

If a high IP (Ingress Protection) rating is required, then a suitable sealing washer must be fitted under the cable glands or blanking plugs. A minimum ingress protection rating of IP6X must be maintained for installations in explosive dust atmospheres.

For combustible dust applications, the cable entry device and blanking elements shall be in type of explosion protection and shall have an IP 6X rating.

Adapters

The STEx sounder range can be supplied with the following types of adapters:

- M20 to 1/2" NPT
- M20 to 3/4" NPT
- M20 to M25

It is important to note that stopping plugs cannot be fitted onto adapters, only directly onto the M20 entries.

Any other adapters used must be suitably rated and certified adapters.

8 Settings

Following illustrations show the different settings available for STExS1 Alarm Horn Sounders. See schematic diagrams D190-06-001 for DC units and D190-06-005 for AC units.

8.1 SPL Configuration

See Table 1 for product power supply and Sound Pressure Levels (SPL).

Configuration for DC Units

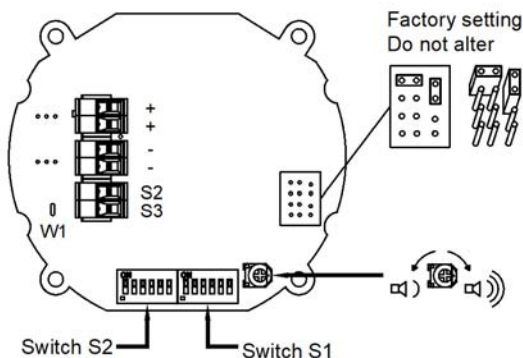

Figure 6: DC PCBA SPL Configuration.

Configuration for AC Units

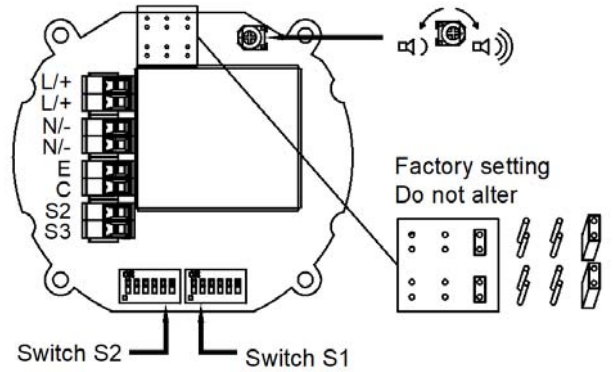

Figure 7: AC PCBA SPL Configuration.

8.2 Stage Switching Polarity (DC Units)

Switching from positive switching (default) to negative switching - DC Only.

NOTE: Max supply is 33V DC – if higher DC voltage is required, use Negative switching.

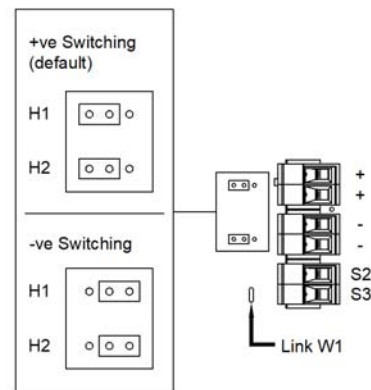

Figure 8: Stage Switching Polarity.

8.3 Tone Selection

The STExS Alarm Horn Sounders have 64 different tones that can be selected independently for the first and second stage alarms. The tones are selected by operation of the tone setting DIP switch 1 & DIP switch 2 (see figures 6 and 7) on the PCB, for stage 1 and stage 2 respectively.

Default = S2 – Tone 1

Default = S1 – Tone 44

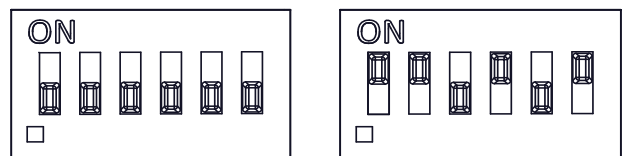

(ON = 1, OFF = 0)

Figure 9: DIP switch configuration

The sounder can also be switched to sound the third and fourth stage alarm tones.

The tone table (D221-95-001-IS) shows the switch positions for the 64 tones on first and second stages and which tones are available for the third and fourth stages dependent on the Stage 1 DIP switch setting.

Following table (Table 4) is a summary of the wiring options.

Config.	Voltage	Configuration Description	Features	Product Option Identifier
See documents D190-06-001 for DC schematic diagrams.				
1a	DC	Single Stage Configuration	<ul style="list-style-type: none"> Line monitoring (refer section 10) Positive Switching 	1
1b	DC	Two Stage Configuration	<ul style="list-style-type: none"> Common Negative Positive Switching Line monitoring (refer section 10) 	1
1c	DC	Three/Four Stage Configuration	<ul style="list-style-type: none"> Common Negative Positive Switching Line monitoring (refer section 10) 	1
2	DC	Three/Four Stages. Voltage Free 2nd, 3rd & 4th Stage Activation Configuration	<ul style="list-style-type: none"> Common Positive Customer Set H1 & H2 to Negative Switching Line monitoring (refer section 10) 	1
3	DC	Two Stage Configuration	<ul style="list-style-type: none"> Independent Stage Input Reverse Polarity Monitoring Stage 1 & 2 (refer to section 10) 	1
4	DC	Two Stage Configuration	<ul style="list-style-type: none"> Independent power input for alarm stage activation of Stage 1 & 2. Line monitoring available for each alarm stage – use suitable monitoring relays/modules. Line monitoring requires common negative between each power input. Line monitoring maximum voltage: 4Vdc. Not to be used for reverse polarity line monitoring. 	Y
5	DC	Two/Three Stage Voltage Free Activation Configuration	<ul style="list-style-type: none"> Line monitoring (refer section 10) 	K
6	DC	Three/Four Stage Configuration	<ul style="list-style-type: none"> Independent power input for alarm stage activation of Stage 1, 2 and 3 Stage 4 can be activated via activation of Stage 2 and Stage 3 simultaneously Line monitoring available for Stage 1, 2 & 3 alarm stage – use suitable monitoring relays/modules Line monitoring requires common negative between each power input Line monitoring maximum voltage: 4Vdc Not to be used for reverse polarity line monitoring 	V
See documents D190-06-005 for AC schematic diagrams.				
1a	AC	Single Stage Configuration		1
1b	AC	Three/Four Stage Configuration		1
2	AC	Two/Three Stage Voltage Free Activation Configuration		K

Table 4: Summary of Wiring Options.

9 End of Line Monitoring (DC Units)

All DC units have a blocking diode fitted in their supply input lines. An end of line monitoring diode or an end of line monitoring resistor can be connected across the +ve and -ve terminals in the flameproof chamber. See D190-06-001 for details.

If an end of line resistor is used it must have a minimum resistance value of 3k3 ohms and a minimum wattage of 0.5W or a minimum resistance value of 500 ohms and a minimum wattage of 2W.

The resistor must be connected directly across the +ve and -ve terminals as shown in the following drawing. The resistor leads should be kept as short as possible.

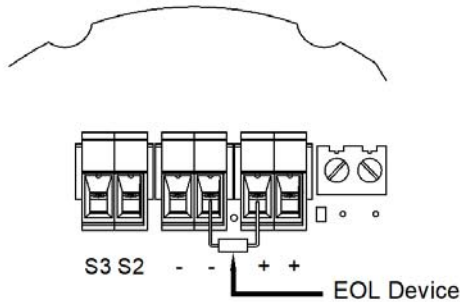

Figure 10: End of Line Resistor placement.

Note: For forward voltage polarity line monitoring the maximum voltage is 4Vdc. For wiring configuration 4 (product option Y) and configuration 6 (product option V) line monitoring requires common negative between each power input. For monitoring voltage, the installer should allow for system cabling and voltage drops

9.1 Custom DC Multi-Stage End Of Line Monitoring

An optional 12-way terminal module is available to enable up to four alarm stages to be activated from three DC voltage output channels. The three alarm stage activation inputs can be independently monitored.

Refer to Schematic D190-06-001, Config. 6.
Specify Product option 'V' when ordering.
Spare part code for field installation: SP78-0001

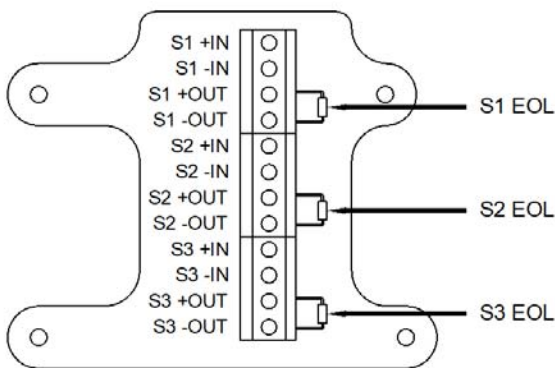

Figure 11: End of Line Resistor placement – Optional 12-Way Terminal Module.

10 Maintenance, Overhaul and Repair

Maintenance, repair and overhaul of the equipment should only be carried out by suitably qualified personnel in accordance with the current relevant standards.

ATEX / IECEx & UKEx Requirements Only

EN60079-19/IEC60079-19

Explosive atmospheres – Equipment repair, overhaul and reclamation

EN 60079-17/IEC60079-17

Explosive atmospheres – Electrical installations inspection and maintenance

Repair of the flameproof threaded joints and cemented joints is not permitted.

Units must not be opened while an explosive atmosphere is present.

If opening the unit during maintenance operations a clean environment must be maintained and any dust layer removed prior to opening the unit.

Potential electrostatic charging hazard - Clean only with a damp cloth.

11 SIL 2 Reliability Data

Reliability and Functional safety IEC/EN61508 which has been assessed and is considered suitable for use in low demand safety function:

1. Random Hardware Failures and Architectural constraints (route 2+).
2. As an unvoted item (i.e. hardware fault tolerance of 0) at SIL 2. The product was assessed against failure modes:
 - Failure respond to an input by sounding sounder.
 - Spurious sound output despite no input.
3. When employing the device in a SIL2 compliant system the user should ensure frequent or continuous automatic monitoring of continuity.

Integrity in respect of failure to function	SIL2 & SIL1
Total Failure rate	0.55 pmh
"Hazardous" failure rate (revealed)	0 pmh
"Hazardous" failure rate (unrevealed)	0.55 pmh
"Safe" failure rate (revealed)	0 pmh
"Safe" failure rate (unrevealed)	0
System type	B
Hardware Fault Tolerance	0
Diagnostic Coverage	>80%
PFD (hazardous failure)	2.4×10^{-3}
Proof Test Interval	Up to 1 year

Stage 1 Set DIP SW 1 Tone No.	Tone Description	Tone Visual	Stage 1 & 2 DIP SW 1/2 Settings 1 2 3 4 5 6	Stage 3 Set DIP SW 1 (S3)	Stage 4 Set DIP SW 1 (S2 + S3)
1	1000Hz PFEER Toxic Gas		0 0 0 0 0	2	44
2	1200/500Hz @ 1Hz DIN /PFEER P.T.A.P.		1 0 0 0 0	3	44
3	1000Hz @ 0.5Hz(1s on, 1soff) PFEER Gen. Alarm		0 1 0 0 0 0	2	44
4	1.4KHz-1.6KHz 1s, 1.6KHz-1.4KHz 0.5s NF C 48-265		1 1 0 0 0 0	24	1
5	544Hz(100mS)/440Hz (400mS) NF S 32-001		0 0 1 0 0 0	19	1
6	1500/500Hz - (0.5s on , 0.5s off) x3 + 1s gap AS4428		1 0 1 0 0 0	44	1
7	500-1500Hz Sweeping 2 sec on 1 sec off AS4428		0 1 1 0 0 0	44	1
8	500/1200Hz @ 0.26Hz (3.3son, 0.5s off) Netherlands - NEN 2575		1 1 1 0 0 0	24	35
9	1000Hz (1s on, 1s off)x7 + (7s on, 1s off) IMO Code 1a		0 0 0 1 0 0	34	1
10	1000Hz (1s on, 1s off)x7 + (7s on, 1s off) IMO Code 1a		1 0 0 1 0 0	34	1
11	420Hz(0.5s on, 0.5s off)x3 + 1s gap ISO 8201 Temporal Pattern		0 1 0 1 0 0	1	8
12	1000Hz(0.5s on, 0.5s off)x3 + 1s gap ISO 8201 Temporal Pattern		1 1 0 1 0 0	1	8
13	422/775Hz - (0.85 on, 0.5 off) x3 + 1s gap NFPA - Temporal Coded		0 0 1 1 0 0	1	8
14	1000/2000Hz @ 1Hz Singapore		1 0 1 1 0 0	3	35
15	300Hz Continuous (f=300)		0 1 1 1 0 0	24	35
16	440Hz Continuous (f=440)		1 1 1 1 0 0	24	35
17	470Hz Continuous (f=470)		0 0 0 0 1 0	24	35
18	500Hz Continuous IMO code 2 (Low) (f=500)		1 0 0 0 1 0	24	35
19	554Hz Continuous (f=554)		0 1 0 0 1 0	24	35
20	660Hz Continuous (f=660)		1 1 0 0 1 0	24	35
21	800Hz IMO code 2 (High) (f=800)		0 0 1 0 1 0	24	35
22	1200Hz Continuous (f=1200)		1 0 1 0 1 0	24	35
23	2000Hz Continuous (f=2000)		0 1 1 0 1 0	3	35
24	2400Hz Continuous (f=2400)		1 1 1 0 1 0	20	35
25	440Hz @0.83Hz (50 cycles/minute) Intermittent (f=440, a=0.6, b=0.6)		0 0 0 1 1 0	44	8
26	470Hz @0.9Hz - 1.1s Intermittent (f=470, a=0.55, b=0.55)		1 0 0 1 1 0	44	8
27	470Hz @5Hz - (5 cycles/second) Intermittent (f=470, a=0.1, b=0.1)		0 1 0 1 1 0	44	8
28	544Hz @ 1.14Hz - 0.875s Intermittent (f=470, a=0.43, b=0.44)		1 1 0 1 1 0	24	8
29	655Hz @ 0.875Hz Intermittent (f=655, a=0.57, b=0.57)		0 0 1 1 1 0	44	8
30	660Hz @0.28Hz - 1.8sec on, 1.8sec off Intermittent (f=660, a=1.8, b=1.8)		1 0 1 1 1 0	24	8
31	660Hz @3.34Hz - 150mS on, 150mS off Intermittent (f=660, a=0.15, b=0.15)		0 1 1 1 1 0	24	8
32	745Hz @ 1Hz Intermittent (f=745, a=0.5, b=0.5)		1 1 1 1 1 0	24	8
33	800Hz - 0.25sec on, 1 sec off Intermittent (f=800, a=0.25, b=1)		0 0 0 0 0 1	24	8
34	800Hz @ 2Hz IMO code 3.a (High) Intermittent (f=800, a=0.25, b=0.25)		1 0 0 0 0 1	24	8
35	1000Hz @ 1Hz Intermittent (f=1000, a=0.5, b=0.5)		0 1 0 0 0 1	24	8
36	2400Hz @ 1Hz Intermittent (f=2400, a=0.5, b=0.5)		1 1 0 0 0 1	24	8
37	2900Hz @ 5Hz Intermittent (f=2900, a=0.1, b=0.1)		0 0 1 0 0 1	24	8
38	363/518Hz @ 1Hz Alternating (f=363, f1=518, a=0.1)		1 0 1 0 0 1	8	19
39	450/500Hz @ 2Hz Alternating (f=450, f1=500, a=0.25)		0 1 1 0 0 1	8	19
40	554/440Hz @ 1Hz Alternating (f=440, f1=554, a=0.5)		1 1 1 0 0 1	24	19
41	554/440Hz @ 0.625Hz Alternating (f=440, f1=554, a=0.8)		0 0 0 1 0 1	8	19
42	561/760Hz @0.83Hz (50 cycles/minute) Alternating (f=561, f1=760, a=0.6)		1 0 0 1 0 1	8	19
43	780/600Hz @ 0.96Hz Alternating (f=600, f1=780, a=0.52)		0 1 0 1 0 1	8	19
44	800/1000Hz @ 2Hz Alternating (f=800, f1=1000, a=0.25)		1 1 0 1 0 1	24	19
45	970/800Hz @ 2Hz Alternating (f=800, f1=970, a=0.25)		0 0 1 1 0 1	8	19
46	800/1000Hz @ 0.875Hz Alternating (f=800, f1=1000, a=0.57)		1 0 1 1 0 1	24	19
47	2400/2900Hz @ 2Hz Alternating (f=2400, f1=2900, a=0.25)		0 1 1 1 0 1	24	19
48	500/1200Hz @ 0.3Hz Sweeping (f=500, f1=1200, a=3.34)		1 1 1 1 0 1	24	12
49	560/1055Hz @ 0.18Hz Sweeping (f=560, f1=1055, a=5.47)		0 0 0 0 1 1	24	12
50	560/1055Hz @ 3.3Hz Sweeping (f=560, f1=1055, a=0.3)		1 0 0 0 1 1	24	12
51	600/1250Hz @ 0.125Hz Sweeping (f=600, f1=1250, a=8)		0 1 0 0 1 1	24	12
52	660/1200Hz @ 1Hz Sweeping (f=660, f1=1200, a=1)		1 1 0 0 1 1	24	12
53	800/1000Hz @ 1Hz Sweeping (f=800, f1=1000, a=1)		0 0 1 0 1 1	24	12
54	800/1000Hz @ 7Hz Sweeping (f=800, f1=1000, a=0.14)		1 0 1 0 1 1	24	12
55	800/1000Hz @ 50Hz Sweeping (f=800, f1=1000, a=0.02)		0 1 1 0 1 1	24	12
56	2400/2900Hz @ 7Hz Sweeping (f=2400, f1=2900, a=0.14)		1 1 1 0 1 1	24	12
57	2400/2900Hz @ 1Hz Sweeping (f=2400, f1=2900, a=1)		0 0 0 1 1 1	24	12
58	2400/2900Hz @ 50Hz Sweeping (f=2400, f1=2900, a=0.02)		1 0 0 1 1 1	24	12
59	2500/3000Hz @ 2Hz Sweeping (f=2500, f1=3000, a=0.5)		0 1 0 1 1 1	24	12
60	2500/3000Hz @ 7.7Hz Sweeping (f=2500, f1=3000, a=0.13)		1 1 0 1 1 1	24	12
61	800Hz Motor Siren (f=800, a=1.6)		0 0 1 1 1 1	24	12
62	1200Hz Motor Siren (f=1200, a=2)		1 0 1 1 1 1	24	12
63	2400Hz Motor Siren (f=2400, a=1.7)		0 1 1 1 1 1	24	12
64	Simulated Bell		1 1 1 1 1 1	21	12

1	2	3	4	5	6	7	8	9	10
							ISSUE	MOD No.	REASON - INITIAL - DATE
							1		INTRODUCTION RSR - 19/01/2022
							2	ACN0141	EOL VALUES AMENDED RSR - 20/12/2023
							3	ACN0153	OPTIONS Y & V MONITORING DETAILS RSR - 06/06/2024

OPTIONAL LINE MONITORING RESISTOR, CUSTOMER SUPPLIED,
MINIMUM EOL RESISTOR VALUES
500Ω MIN AT 2W MIN OR 3.3KΩ MIN AT 0.5W MIN



Single Stage Configuration	Config.: 1a	Two Stage Configuration	Config.: 1b	Three/Four Stage Configuration	Config.: 1c
Line Monitoring Set to positive switching (default)		Common Negative Set to positive switching (default)		Common Negative Set to positive switching (default)	
Stage 1: Apply Power to Stage 1 +ve & Stage 1 -ve		Stage 1: Apply Power to Stage 1 +ve & Common -ve Stage 2: Apply Power to Stage 2 +ve & Common -ve		Stage 1: Apply Power to Stage 1 +ve & Common -ve Stage 2: Apply Power to Stage 2 +ve & Common -ve Stage 3: Apply Power to Stage 3 +ve & Common -ve Stage 4: Apply Power to Stage 2 +ve, Stage 3 +ve & Common -ve	

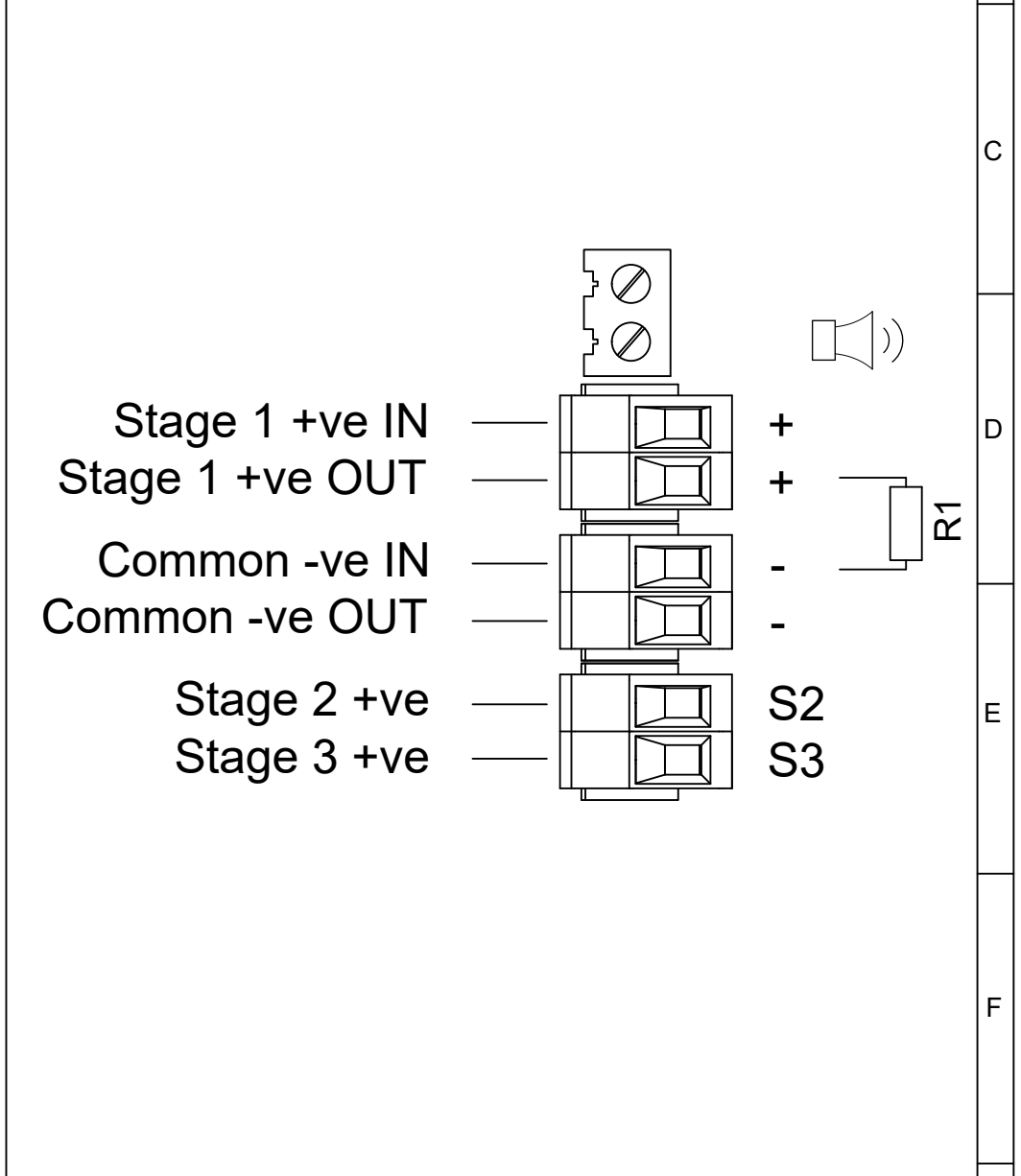
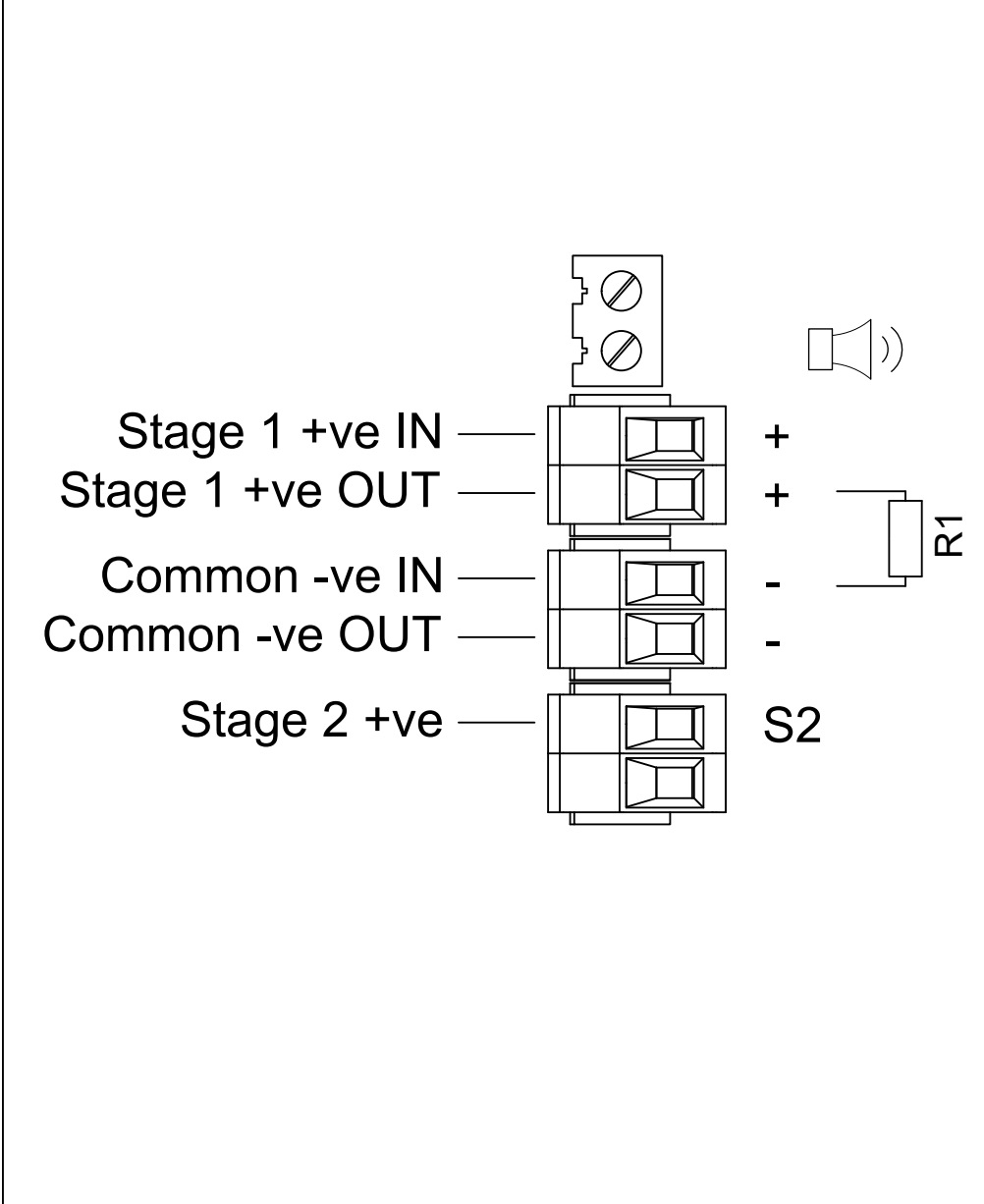
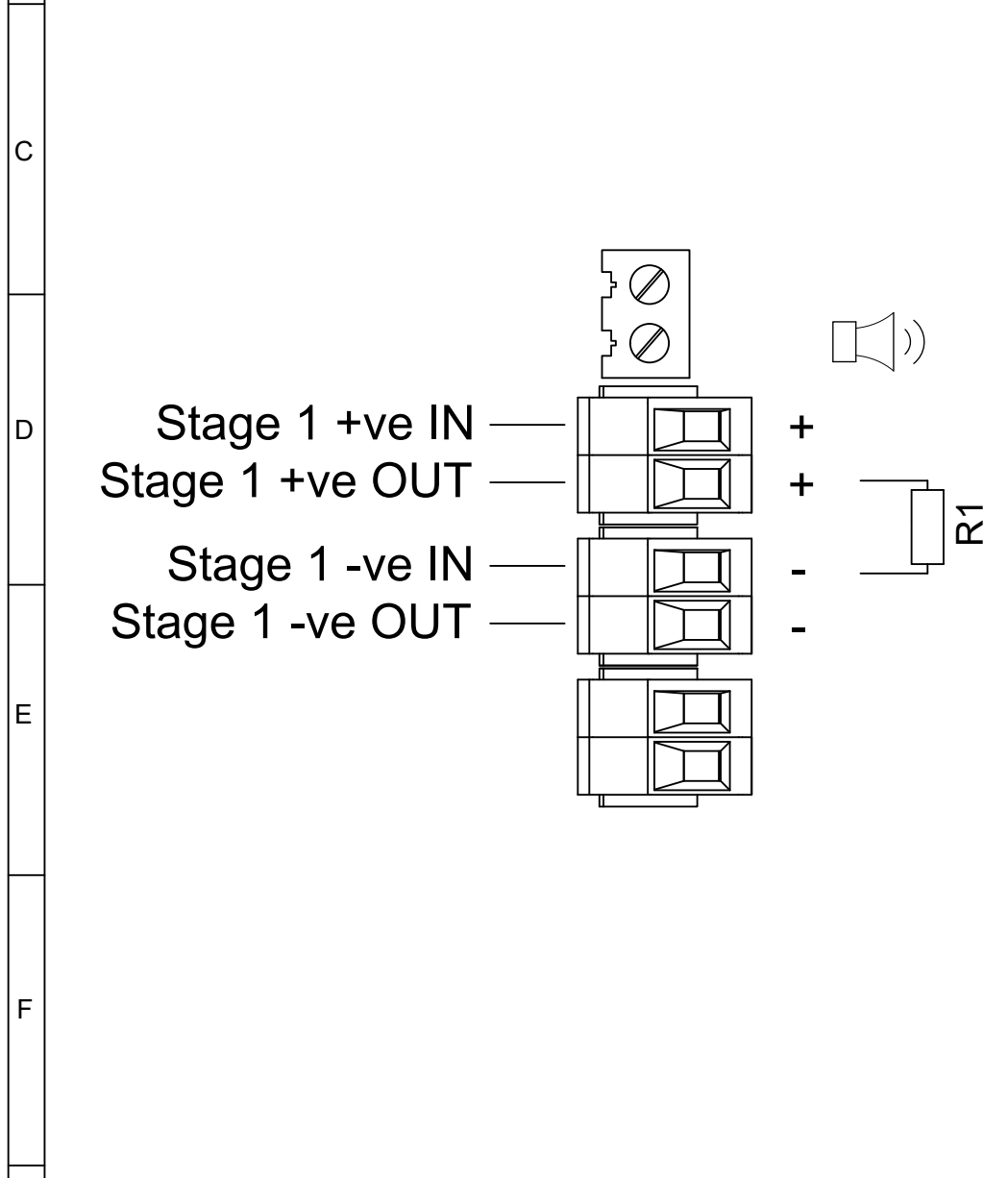

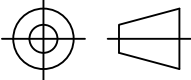
DRAWING TO BS8888:2000 GEOMETRIC TOLERANCES TO ISO1101:1983 LINEAR DIMENSIONAL TOLS ANGULAR DIMENSIONAL TOLS	DRAWN	DATE	SURFACE FINISH	WEIGHT (Kg)	THIS DRAWING AND ANY INFORMATION OR DESCRIPTIVE MATTER THEREIN IS COMMUNICATED IN CONFIDENCE AND IS THE COPYRIGHT PROPERTY OF EUROPEAN SAFETY SYSTEMS LTD. NEITHER THE WHOLE OR ANY EXTRACT MAY BE DISCLOSED, LOANED, COPIED OR USED FOR MANUFACTURING OR TENDERING PURPOSES WITHOUT THEIR WRITTEN CONSENT.	 EUROPEAN SAFETY SYSTEMS LTD IMPRESS HOUSE MANSELL ROAD ACTON LONDON W3 7QH WWW.E2S.COM	ALL DIMENSIONS IN MM			A3
	R.S.RAIT	19/01/2022					IF IN DOUBT, ASK - DO NOT SCALE			
	CHECKED	DATE	MATERIAL				TITLE D1xS1 / D1xS2 / GNExS1 / GNExS2 / STExS1 / STExS2 DC SOUNDER WIRING DIAGRAMS			
	B.ISARD	19/01/2022	ALTERNATIVE MATERIAL				SCALE	SHEET	DRAWING NUMBER	
STANDARDS	APPROVED	DATE	© EUROPEAN SAFETY SYSTEMS LTD. AS PER LATEST DATE OF ISSUE SHOWN ABOVE			WWW.E2S.COM		NTS	1 OF 3	D190-06-001
D1x	R.N.POTTS	19/01/2022								

1	2	3	4	5	6	7	8	9	10
							ISSUE	MOD No.	REASON - INITIAL - DATE
							1		INTRODUCTION RSR - 19/01/2022
							2	ACN0141	EOL VALUES AMENDED RSR - 20/12/2023
							3	ACN0153	OPTIONS Y & V MONITORING DETAILS RSR - 06/06/2024

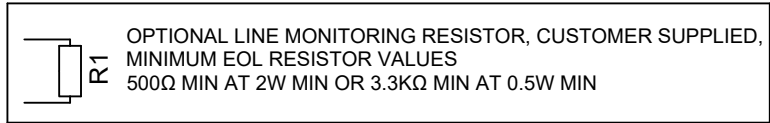

Three/Four Stages. Voltage Free 2nd, 3rd & 4th Stage Activation Configuration Config.: 2 Two Stage Configuration Config.: 3

Common Positive Independent Stage Input
 Customer Set H1 & H2 to Negative Switching (See Below) Reverse Polarity Stage Monitoring

Stage 1: Apply Power to Common +ve & Stage 1 -ve
 Stage 2: Apply Power to Common +ve & Stage 1 -ve & connect Stage 2 -ve to Stage 1 -ve
 Stage 3: Apply Power to Common +ve & Stage 1 -ve & connect Stage 3 -ve to Stage 1 -ve
 Stage 4: Apply Power to Common +ve & Stage 1 -ve
 & connect Stage 2 -ve & Stage 3 -ve to Stage 1 -ve

Stage 1: Apply Power to Stage 1 +ve & Stage 1 -ve
 Stage 2: Apply Power to Stage 1 +ve & Stage 1 -ve & connect Stage 2 -ve to Stage 1 -ve

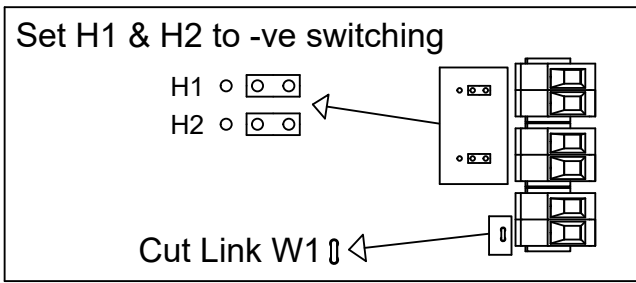
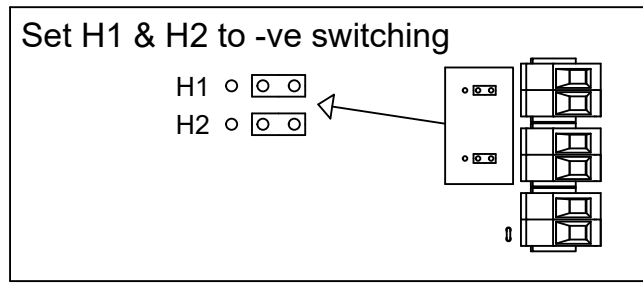
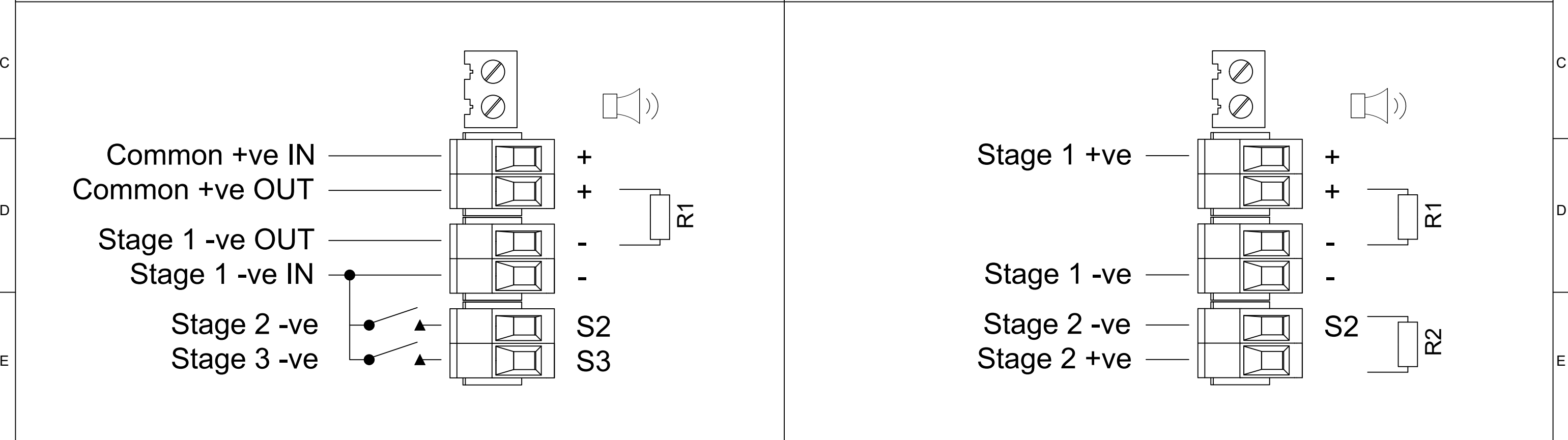

G	DRAWING TO BS8888:2000 GEOMETRIC TOLERANCES TO ISO1101:1983 LINEAR DIMENSIONAL TOLS ANGULAR DIMENSIONAL TOLS	DRAWN R.S.RAIT	DATE 19/01/2022	SURFACE FINISH	WEIGHT (Kg)	THIS DRAWING AND ANY INFORMATION OR DESCRIPTIVE MATTER THEREIN IS COMMUNICATED IN CONFIDENCE AND IS THE COPYRIGHT PROPERTY OF EUROPEAN SAFETY SYSTEMS LTD. NEITHER THE WHOLE OR ANY EXTRACT MAY BE DISCLOSED, LOANED, COPIED OR USED FOR MANUFACTURING OR TENDERING PURPOSES WITHOUT THEIR WRITTEN CONSENT. © EUROPEAN SAFETY SYSTEMS LTD. AS PER LATEST DATE OF ISSUE SHOWN ABOVE	EUROPEAN SAFETY SYSTEMS LTD IMPRESS HOUSE MANSELL ROAD ACTON LONDON W3 7QH WWW.E2S.COM	ALL DIMENSIONS IN MM IF IN DOUBT, ASK - DO NOT SCALE		A3
	STANDARDS D1x	CHECKED B.ISARD	DATE 19/01/2022	MATERIAL	TITLE D1xS1 / D1xS2 / GNExS1 / GNExS2 / STExS1 / STExS2 DC SOUNDER WIRING DIAGRAMS					
		APPROVED R.N.POTTS	DATE 19/01/2022	ALTERNATIVE MATERIAL	SCALE NTS			SHEET 2 OF 3	DRAWING NUMBER D190-06-001	

1	2	3	4	5	6	7	8	9	10
							ISSUE	MOD No.	REASON - INITIAL - DATE
							1		INTRODUCTION RSR - 19/01/2022
							2	ACN0141	EOL VALUES AMENDED RSR - 20/12/2023
							3	ACN0153	OPTIONS Y & V MONITORING DETAILS RSR - 06/06/2024

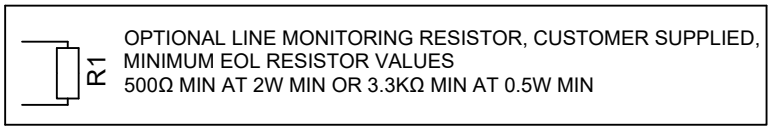

Two Stage Configuration			Config.: 4	Two/Three Stage Voltage Free Activation Configuration			Config.: 5	Three/Four Stage Configuration			Config.: 6
-------------------------	--	--	------------	---	--	--	------------	--------------------------------	--	--	------------

Independent power input for alarm stage activation. Line monitoring available for Stage 1 & 2 alarm stage. Line monitoring requires common negative between each power input. Line monitoring maximum voltage: 4Vdc. Not to be used for reverse polarity line monitoring.				Customer Set H1 & H2 to Negative Switching (See Below)				Independent power input for alarm stage activation. Line monitoring available for Stage 1, 2 & 3 alarm stage. Line monitoring requires common negative between each power input. Line monitoring maximum voltage: 4Vdc. Not to be used for reverse polarity line monitoring.			
---	--	--	--	--	--	--	--	--	--	--	--

Stage 1: Apply Power to Stage 1 +ve & Stage 1 -ve Stage 2: Apply Power to Stage 2 +ve & Stage 2 -ve				Power: +ve & -ve Stage 1: Connect Stage 1 -ve to Common -ve Stage 2: Connect Stage 2 -ve to Common -ve Stage 3: Connect both Stage 1 -ve & Stage 2 -ve to Common -ve				Stage 1: Apply Power to Stage 1 +ve & Stage 1 -ve Stage 2: Apply Power to Stage 2 +ve & Stage 2 -ve Stage 3: Apply Power to Stage 3 +ve & Stage 3 -ve Stage 4: Apply Power to Stage 2 +ve & Stage 2 -ve & Apply Power to Stage 3 +ve & Stage 3 -ve			
--	--	--	--	---	--	--	--	---	--	--	--

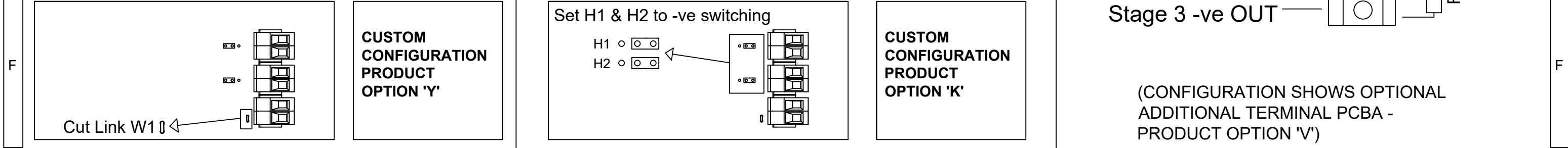
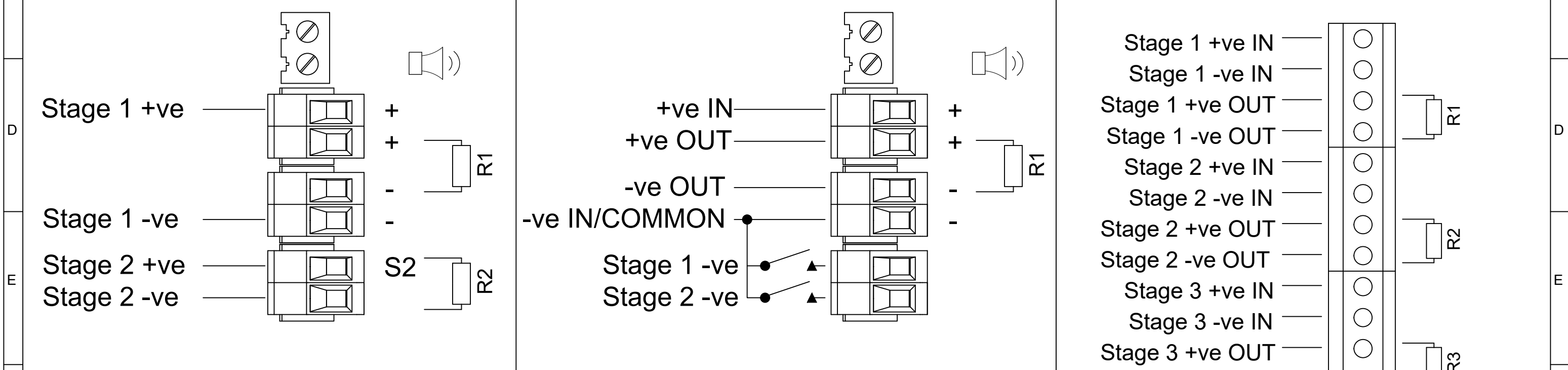

DRAWING TO BS8888:2000 GEOMETRIC TOLERANCES TO ISO1101:1983 LINEAR DIMENSIONAL TOLS ANGULAR DIMENSIONAL TOLS	DRAWN R.S.RAIT	DATE 19/01/2022	SURFACE FINISH	WEIGHT (Kg)	THIS DRAWING AND ANY INFORMATION OR DESCRIPTIVE MATTER THEREIN IS COMMUNICATED IN CONFIDENCE AND IS THE COPYRIGHT PROPERTY OF EUROPEAN SAFETY SYSTEMS LTD. NEITHER THE WHOLE OR ANY EXTRACT MAY BE DISCLOSED, LOANED, COPIED OR USED FOR MANUFACTURING OR TENDERING PURPOSES WITHOUT THEIR WRITTEN CONSENT. © EUROPEAN SAFETY SYSTEMS LTD. AS PER LATEST DATE OF ISSUE SHOWN ABOVE	EUROPEAN SAFETY SYSTEMS LTD IMPRESS HOUSE MANSELL ROAD ACTON LONDON W3 7QH WWW.E2S.COM	ALL DIMENSIONS IN MM IF IN DOUBT, ASK - DO NOT SCALE		A3
	CHECKED B.ISARD	DATE 19/01/2022	MATERIAL	TITLE D1xS1 / D1xS2 / GNExS1 / GNExS2 / STExS1 / STExS2 DC SOUNDER WIRING DIAGRAMS					
	STANDARDS D1x	APPROVED R.N.POTTS	DATE 19/01/2022	ALTERNATIVE MATERIAL			SCALE NTS	SHEET 3 OF 3	DRAWING NUMBER D190-06-001



Single Stage Configuration	Config.: 1a	Three/Four Stage Configuration	Config.: 1b	Two Stage Voltage Free Activation Configuration	Config.: 2	
Stage 1: Apply Power to Stage 1 Live & Stage 1 Neutral		Stage 1: Apply Power to Live & Neutral Stage 2: Apply Power to Live & Neutral & connect Stage 2 to Common Stage 3: Apply Power to Live & Neutral & connect Stage 3 to Common Stage 4: Apply Power to Live & Neutral & connect both Stage 2 & Stage 3 to Common		Power: Live & Neutral Stage 1: Connect Stage 1 to Common Stage 2: Connect Stage 2 to Common Stage 3: Connect both Stage 1 & Stage 2 to Common		

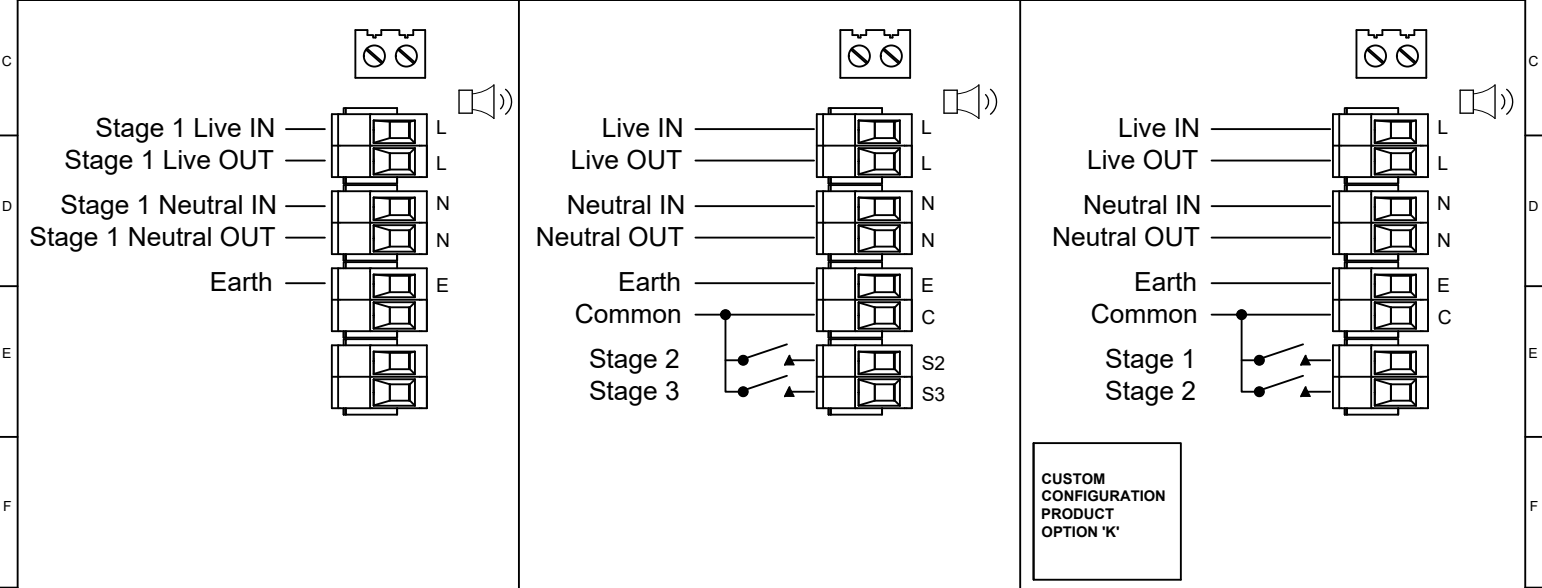

CUSTOM CONFIGURATION PRODUCT OPTION 'K'

DRAWING TO BS8888:2000 GEOMETRIC TOLERANCES TO ISO1101:1983 LINEAR DIMENSIONAL TOLS ANGULAR DIMENSIONAL TOLS	DRAWN	DATE	SURFACE FINISH	WEIGHT (Kg)	THIS DRAWING AND ANY INFORMATION OR DESCRIPTIVE MATTER THEREIN IS COMMUNICATED IN CONFIDENCE AND IS THE COPYRIGHT PROPERTY OF EUROPEAN SAFETY SYSTEMS LTD. NEITHER THE WHOLE OR ANY EXTRACT MAY BE DISCLOSED, LOANED, COPIED OR USED FOR MANUFACTURING OR TENDERING PURPOSES WITHOUT THEIR WRITTEN CONSENT. © EUROPEAN SAFETY SYSTEMS LTD. AS PER LATEST DATE OF ISSUE SHOWN ABOVE	 EUROPEAN SAFETY SYSTEMS LTD IMPRESS HOUSE MANSELL ROAD LONDON W3 7QH WWW.E2S.COM	ALL DIMENSIONS IN MM IF IN DOUBT, ASK - DO NOT SCALE		A3
	CHECKED	DATE	MATERIAL				TITLE D1xS1 / D1xS2 / GNExS1 / GNExS2 / STExS1 / STExS2 AC SOUNDER WIRING DIAGRAMS		
	STANDARDS		DATE	ALTERNATIVE MATERIAL			SCALE NTS SHEET 1 of 1 DRAWING NUMBER D190-06-005		
D1x	R.S.RAIT	19/01/2022							
	B.ISARD	19/01/2022							
	R.N.POTTS	19/01/2022							

EU Declaration of Conformity



Manufacturer: European Safety Systems Ltd.
Impress House, Mansell Road, Acton
London, W3 7QH
United Kingdom

Authorised Representative: E2S Warnsignaltechnik UG
Charlottenstrasse 45-51
72764 Reutlingen
Germany

Equipment Type: STExS1, STExS2, STExL1, STExL2
STExB2X05, STExB2X10, STExB2X15, STExB2X21
STExB2LD2, STExB2RT1
STExC1X05
STExJ2

Directive 2014/34/EU: Equipment and Protective Systems for use in Potentially Explosive Atmospheres (ATEX)

Notified Body for EU type Examination (Module B):	UL International Demko A/S Notified Body No.: 0539 Borupvang 5A, 2750 Ballerup, Denmark
EU-type Examination Certificate (Module B):	DEMKO 16ATEX1466X
Notified Body for Quality Assurance Notification / Conformity to EU-type based on quality assurance of the production process (Module D):	Sira Certification Service Notified Body No.: 2813 CSA Group Netherlands B.V, Utrechtseweg 310, 6812 AR, Arnhem, Netherlands
Quality Assurance Notification (Module D):	SIRA 05 ATEX M342
Provisions fulfilled by the equipment:	II 2G Ex db IIC T6...T3 Gb II 2D Ex tb IIIC T82°C...T137°C Db IP6X Dust Protection to EN60079-0 / EN60079-31
Standards applied:	EN IEC 60079-0: 2018 EN 60079-1: 2014 EN 60079-31: 2014

Directive 2014/30/EU: Electromagnetic Compatibility Directive (EMC)

Standards applied:	EN 61000-6-1:2007 EN 61000-6-2:2005 EN 61000-6-3:2007 / A1:2011 / AC: 2012 EN 61000-6-4:2007 / A1: 2011
--------------------	--

Directive 2011/65/EU: Restriction of the use of certain hazardous substances in electrical and electronic equipment (RoHS)

The product and all the components contained within it are in accordance with the restriction of the use of hazardous substances in electrical and electronic equipment, including amendment by Directive 2015/863/EU.

Regulation (EC) 1907/2006: Registration, Evaluation, Authorisation and Restriction of Chemicals (REACH)

The product and all the components contained within it are free from substances of very high concern.

Other Standards and Regulations

EN 60529:1991 / A1:2000 / A2:2013 - Degrees of protection provided by enclosures (IP code) – enclosure rated IP66

EU Declaration of Conformity



On behalf of European Safety Systems Ltd., I declare that, on the date the equipment accompanied by this declaration is placed on the market, the equipment conforms with all technical and regulatory requirements of the above listed directives, regulations and standards.

This Declaration is issued under the sole responsibility of the manufacturer.

A handwritten signature in black ink, appearing to read 'Martin Streetz'.

Martin Streetz
Quality Assurance Manager

Document No.: DC-070_Issue_G
Date and Place of Issue: London, 03/12/2021



UKCA Declaration of Conformity



Manufacturer: European Safety Systems Ltd.
Impress House, Mansell Road, Acton
London, W3 7QH
United Kingdom

Equipment Type: STExS1, STExS2, STExL1, STExL2
STExB2X05, STExB2X10, STExB2X15, STExB2X21
STExB2LD2, STExB2RT1
STExC1X05
STExJ2

Directive UKSI 2016:1107 (as amended by UKSI 2019:696) – Schedule 3A, Part 1 : Product or Protective System Intended for use in Potentially Explosive Atmospheres (UKCA)

Notified Body for UK type Examination (Module B):	UL International (UK) Ltd Notified Body No.: 0843 Unit 1-3 Horizon Kingsland Business Park, Wade Road, Basingstoke, Hampshire RG24 8AH UK
UK-type Examination Certificate (Module B):	UL21UKEX2019X
Notified Body for Quality Assurance Notification / Conformity to EU-type based on quality assurance of the production process (Module D):	Sira Certification Service Notified Body No.: 0518 Rake Lane, Eccleston, Chester CH4 9JN, UK
Quality Assurance Notification (Module D):	CSAE 22UKQAN0046
Provisions fulfilled by the equipment:	II 2G Ex db IIC T6...T3 Gb II 2D Ex tb IIIC T85°C...T137°C Db IP6X Dust Protection to EN60079-0 / EN60079-31
Standards applied:	EN IEC 60079-0: 2018 EN 60079-1: 2014 EN 60079-31: 2014

Directive 2014/30/EU: Electromagnetic Compatibility Directive (EMC)

Standards applied:	EN 61000-6-1:2007 EN 61000-6-2:2005 EN 61000-6-3:2007 / A1:2011 / AC: 2012 EN 61000-6-4:2007 / A1: 2011
--------------------	--

Directive 2011/65/EU: Restriction of the use of certain hazardous substances in electrical and electronic equipment (RoHS)

The product and all the components contained within it are in accordance with the restriction of the use of hazardous substances in electrical and electronic equipment, including amendment by Directive 2015/863/EU.

Regulation (EC) 1907/2006: Registration, Evaluation, Authorisation and Restriction of Chemicals (REACH)

The product and all the components contained within it are free from substances of very high concern.

Other Standards and Regulations

EN 60529:1991 / A1:2000 / A2:2013 - Degrees of protection provided by enclosures (IP code) – enclosure rated IP66

UKCA Declaration of Conformity



On behalf of European Safety Systems Ltd., I declare that, on the date the equipment accompanied by this declaration is placed on the market, the equipment conforms with all technical and regulatory requirements of the above listed directives, regulations and standards.

This Declaration is issued under the sole responsibility of the manufacturer.

A handwritten signature in black ink, appearing to read 'Martin Streetz'.

Martin Streetz
Quality Assurance Manager

Document No.: DC-100_Issue_A
Date and Place of Issue: London, 24/02/2022

Page left Intentionally blank

Page left Intentionally blank

Page left Intentionally blank