

INSTRUCTION MANUAL
GNExS2
Alarm Horn Sounder
For use in Flammable Gas Atmospheres

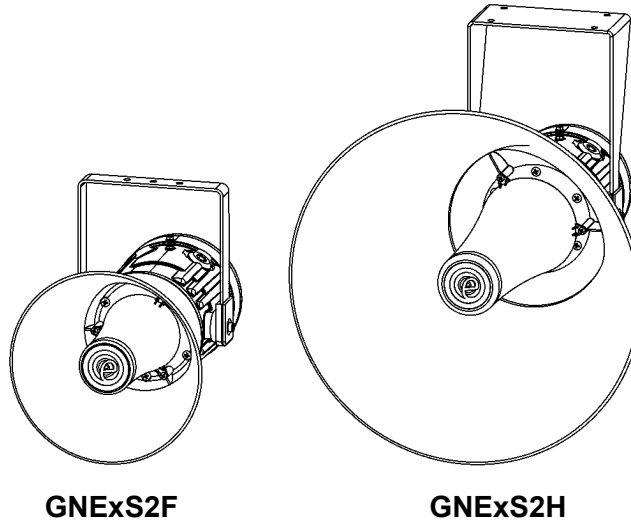

1) Product Table

Model	Nominal Input Voltage	Voltage Range	Nominal Input Current		Max. Current		Sound Pressure Level P2, dB(A)		Sound Pressure Level P3, dB(A)	
			P2	P3	P2	P3	Max*	Nom [†]	Max*	Nom [†]
GNExS2FDC024	12Vdc	10-30Vdc	289mA	356mA	324mA	740mA	120	115	123	118
	24Vdc		324mA	740mA						
GNExS2FDC048	48Vdc	38-60Vdc	195mA	391mA	324mA	740mA	120	115	123	118
GNExS2FAC230	115Vac	100-260Vac 50/60Hz	125mA	282mA	138mA	325mA	120	115	123	118
	230ac		78mA	167mA						
GNExS2HDC024	12Vdc	10-30Vdc	289mA	356mA	324mA	740mA	124	119	127	122
	24Vdc		324mA	740mA						
GNExS2HDC048	48Vdc	38-60Vdc	195mA	391mA	324mA	740mA	124	119	127	122
GNExS2HAC230	115Vac	100-260Vac 50/60Hz	125mA	282mA	138mA	325mA	124	119	127	122
	230Vac		78mA	167mA						

*Max = Tone 4
[†]Nom. = Tone 44

The table shows the input current taken by the various sounders.
The current levels shown above are for the 440Hz Continuous tone @ nominal input voltage at P2 and P3 power setting.
Nominal current at nominal voltage.
Max rated current at worst case supply voltage.

Table 1: Electrical Ratings.

Ensure the system power supply is capable of providing the maximum current required for all sounders. Review associated cable size, length and quantity of sounders on each circuit.

2) Warnings



- DO NOT OPEN WHEN ENERGISED.
- DO NOT OPEN WHEN AN EXPLOSIVE ATMOSPHERE IS PRESENT.
- POTENTIAL ELECTROSTATIC CHARGING HAZARD.
- ALL ENTRIES M20 X 1.5MM.
- IF TEMPERATURE EXCEEDS 70°C AT ENTRY OR 80°C AT BRANCHING POINT USE SUITABLE RATED CABLE AND CABLE GLANDS.
- IF OPENING THE UNIT DURING MAINTENANCE OPERATIONS A CLEAN ENVIRONMENT MUST BE MAINTAINED AND ANY DUST LAYER REMOVED PRIOR TO OPENING THE UNIT.

3) Marking & Rating Information

All units have a rating label, which carries the following important information.

Products may have further approvals, see E2S website for further details.

ATEX / IECEx / UKEX Ratings

Standards	
EN60079-0:2018 EN IEC60079-0:2018 General Requirements	
EN60079-1:2014 A/C:2018 EN 60079-1:2014 ed. 7 Flameproof Enclosure 'd'	
Model No:	Rating
GNEs2DC024	Ex db IIC T4 Gb for Ta -60°C to +50°C
GNEs2DC048	Ex db IIC T3 Gb for Ta -60°C to +58°C
GNEs2AC230	Ex db IIB T6 Gb for Ta -60°C to +50°C Ex db IIB T5 Gb for Ta -60°C to +58°C

Certificate No. SIRA 13ATEX1139X
IECEx SIR 13.0029X
CSAE 21UKEX1558X

Epsilon x
Equipment Group
and Category:



II 2G

CE Marking and
Notified Body No.



2813

UKCA Marking and
Notified Body No.



0518

4) Zones, Gas Group, Category and Temperature Classification

The units can be installed in locations with the following conditions:

Area Classification	
Zone 1	Explosive gas air mixture likely to occur in normal operation.
Zone 2	Explosive gas air mixture not likely to occur in normal operation, and if it does, it will only exist for a short time.
Gas Groupings	
Group IIA	Propane
Group IIB	Ethylene
Group IIC	Hydrogen and Acetylene
Temperature Classification for Gas Applications	
T1	450° C
T2	300° C
T3	200° C
T4	135° C
T5	100° C
T6	85° C
Equipment Category	
2G	
Ambient Temperature Range	
GNEs2	-60° C to +58° C
IP Rating	
IP6X to EN/IEC60079-0 IP66 to EN60529	

5) Special Conditions for Safe Use

Repair of the Flame Path is not permitted.

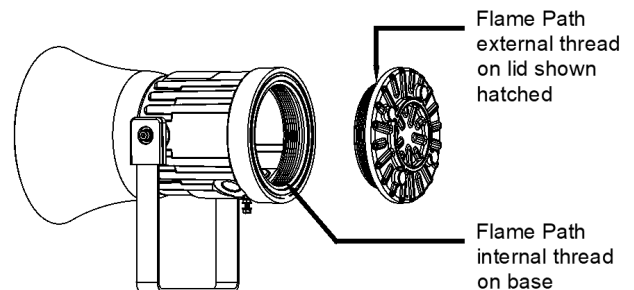

Figure 1: Flame Path.

The enclosure is non-conducting and under certain extreme conditions may generate an ignition capable level of electrostatic charge. The user shall ensure that the equipment is not installed in a location where it may be subjected to extreme conditions (such as high-pressure steam) which might cause a build-up of electrostatic charge on non-conducting surfaces.

6) Product Mounting and Access

6.1 Location and Mounting

The sounder should be secured to any flat surface using the three 7mm fixing holes (see figures 2 or 3). The angle can then be adjusted as required but the mounting restrictions must be observed (see outline drawings for details, D157-05-101 for GNEs2F and D157-05-151 for GNEs2H). This can be achieved by loosening the two large bracket screws in the side of the unit, which allow adjustments in steps of 18°.

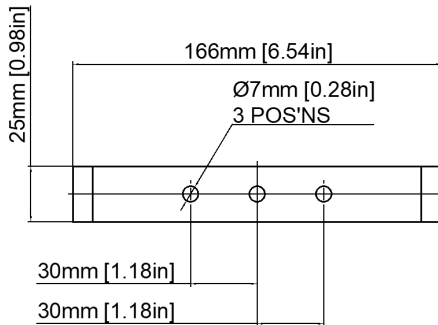

Figure 2: Fixing Location for GNEs2F Sounder.

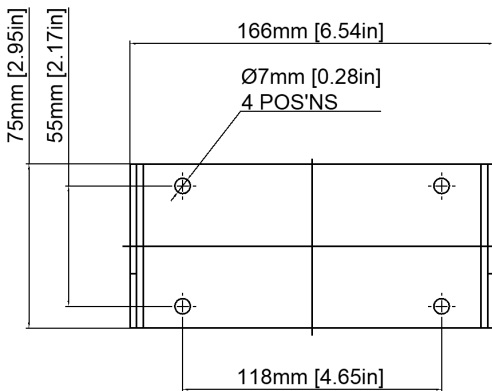

Figure 3: Fixing Location for GNEs2H Sounder.

On completion of the installation the two large bracket adjustment screws on the side of the unit must be fully tightened to ensure that the unit cannot move in service.

The enclosure provides IP66 protection and is suitable for installation in exterior locations providing it is positioned so that water cannot collect in the horn, and the cable entry is sealed.

6.2 Access to the Flameproof Enclosure



Warning – Hot surfaces. External surfaces and internal components may be hot after operation, take care when handling the equipment.

In order to connect the electrical supply cables to the sounder it is necessary to remove the flameproof cover to gain access to the flameproof chamber. To achieve this by loosening the M3 Grub Screw within the flameproof cover, and then unscrew the flameproof cover, taking extreme care not to damage the flameproof joints in the process (see figure 4).

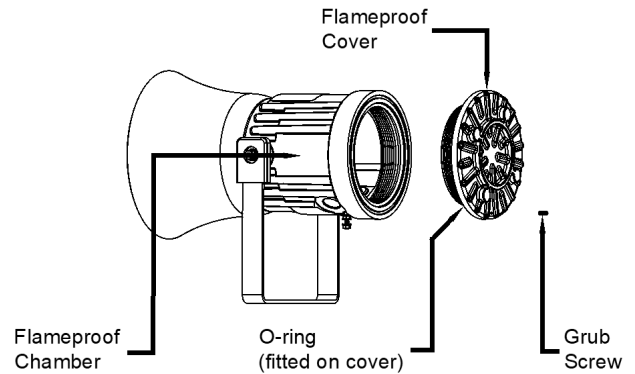

Figure 4: Accessing the Explosion Proof Enclosure.

On completion of the cable wiring installation the flameproof joints should be inspected to ensure that they are clean and that they have not been damaged during installation.

Ensure that the 'O' ring seal is in place and undamaged.

When fitting the flameproof cover ensure the thread is engaged correctly. Fully tighten the cover all the way, ensure no gap is visible between the cover and base of the sounder enclosure. Tighten the M3 grub screw.

7) Installation Requirements

7.1 Installation Standards Compliance



Warning – High voltage may be present, risk of electric shock. DO NOT open when energised, disconnect power before opening.

The sounder must only be installed by suitably qualified personnel in accordance with the latest issues of the relevant standards:

EN60079-14:2008 / IEC60079-14:2007 (Ed4): Electrical Installations in Hazardous Areas (other than mines).

EN60079-10-1:2009 / IEC60079-10:2008 (Ed1): Classification of Areas, Gas Atmosphere

The installation of the units must also be in accordance with any local codes that may apply and should only be carried out by a competent electrical engineer who has the necessary training.

7.2 Cable Selection and Connections

When selecting the cable size, consideration must be given to the input current that each unit draws (see table 1), the number of sounders on the line and the length of the cable runs. The cable size selected must have the necessary capacity to provide the input current to all the sounders connected to the line.

Electrical connections are to be made into the terminal blocks on the PCBA located in the flameproof enclosure using solid wire 0.5-4mm² / AWG 20-12 or stranded wire, sizes 0.5-2.5mm² / AWG 24-14. Wire insulation needs to be stripped 8mm. Wires may be fitted securely with crimped ferrules.

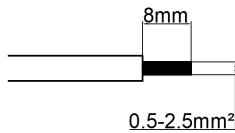

Figure 5: Wire Preparation.

Terminal screws need to be tightened down with a tightening torque of 0.45 Nm / 5 Lb-in. An 8-way terminal block is provided on the AC Sounder, and a 6-way terminal block is provided on the DC Sounder.

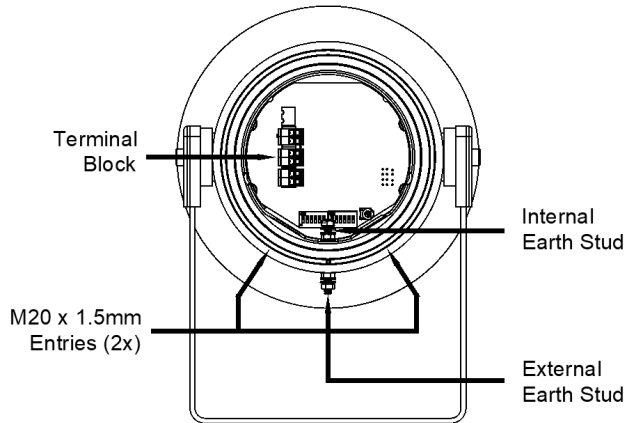

Figure 6: GNExS2 Entries and Terminal Block Location.

When connecting wires to the terminals great care should be taken to dress the wires so that when the cover is inserted into the chamber the wires do not exert excess pressure on the terminal blocks. This is particularly important when using cables with large cross-sectional areas such as 2.5mm².

7.3 Earthing

Please note that for AC supply voltage product versions the Earth terminal on the PCBA does not provide an earth connection to the product enclosure. The enclosure must be independently earthed using either the external or internal earth fixing point, (see fig 6 and notes below).

Both AC and DC sounder units must be connected to an earth according to EN/IEC 60079/14. The units are provided with internal and external earth terminals which are both located on the terminal chamber section of the unit (see figure 6).

Internal earthing connections should be made to the Internal Earth Stud of the housing using a ring crimp terminal to secure the earth conductor between the two M4 stainless steel flat washers. The earth conductor should be at least equal in size and rating to the incoming power conductors.

External earthing connections should be made to the M5 earth stud, using a ring crimp terminal to secure the earth conductor to the earth stud between the two M5 stainless steel flat washers, then reassemble the M5 spring washer and tighten the M5 nut to ensure that the cable lug is secured against loosening and twisting. The external earth conductor should be at least 4mm² in size.

7.4 Cable Glands, Blanking Elements & Adapters

For high ambient temperatures the cable entry or the cable branching point temperatures may exceed:

- 70°C at entry point.
- 80°C at branching point.

Therefore, suitable heat resisting cables and cable glands must be used, with a rated service temperature at least as stated in the table below:

Max Ambient Temperature (°C)							
Model	40	45	50	55	60	65	70
GNExS2	75	80	85	90	95	100	105

Table 2: Min. Ratings of Cables & Cable Glands.

Cable Glands

Appropriate cable glands to be customer supplied.

The cable entries have an M20 x 1.5 – 6H entry thread. Only suitably rated and certified cable glands must be used. They must be suitable for the type of cable being used and also meet the requirements of the current installation standards EN 60079-14 / IEC60079-14.

Blanking Plugs

When only one cable entry is used the other entries must be closed with suitably rated and certified blanking plugs as per type of approval.

Any unused cable entries must be closed with suitably rated blanking plugs.

Ingress Protection

If a high IP (Ingress Protection) rating is required, then a suitable sealing washer must be fitted under the cable glands or blanking plugs. A minimum ingress protection rating of IP6X must be maintained for installations in explosive dust atmospheres.

Adapters

The GNEx sounder range can be supplied with the following types of adapters:

- M20 to ½" NPT
- M20 to ¾" NPT
- M20 to M25

It is important to note that stopping plugs cannot be fitted onto adapters, only directly onto the M20 entries.

Any other adapters used must be suitably rated.

If the installation is made using conduit, openings must have a sealing fitting connected as close as practical to the wall of the enclosure, but in no case more than the size of the conduit or 50mm, whichever is the lesser.

8) Settings

Following illustrations show the different settings available for GNExS2 Alarm Horn Sounders. See schematic diagrams D190-06-001 for DC units and D190-06-005 for AC units.

8.1 SPL Configuration

See Table 1 for product power supply and Sound Pressure Levels (SPL).

Configuration for DC Units

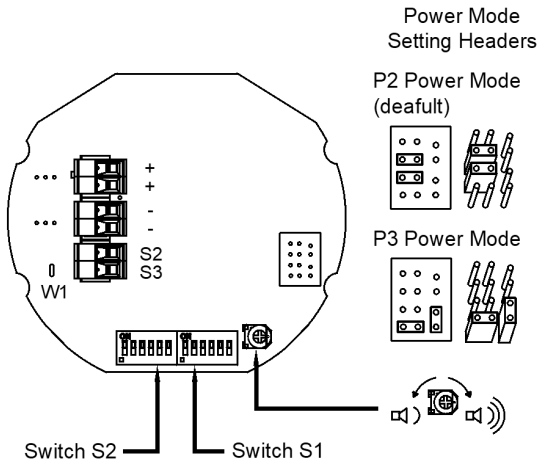

Figure 7: DC PCBA SPL Configuration.

Configuration for AC Units

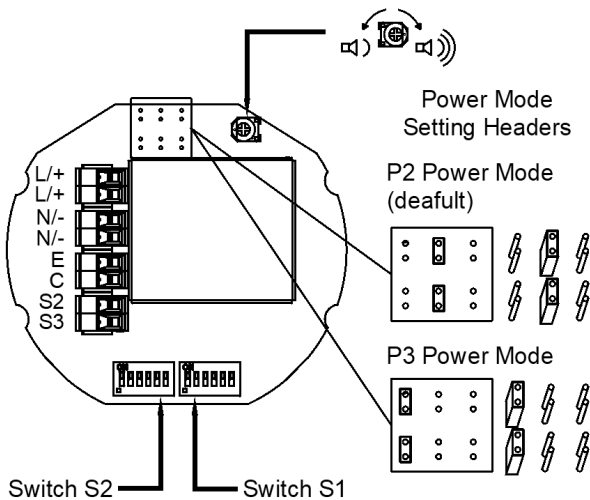

Figure 8: AC PCBA SPL Configuration.

8.2 Stage Switching Polarity (DC Units)

Switching from positive switching (default) to negative switching - DC Only.

NOTE: Max supply is 33V DC – if higher DC voltage is required, use Negative switching.

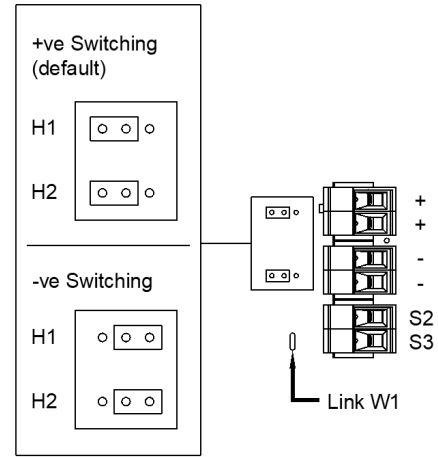
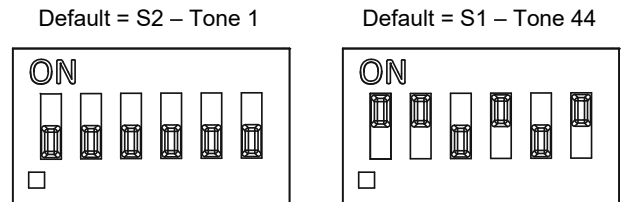

Figure 9: Stage Switching Polarity.

8.3 Tone Selection

The ExS Alarm Horn Sounders have 64 different tones that can be selected independently for the first and second stage alarms. The tones are selected by operation of the tone setting DIP switch 1 & DIP switch 2 (see figures 7 and 8) on the PCB, for stage 1 and stage 2 respectively.



(ON = 1, OFF = 0)

Figure 10: DIP switch configuration

The sounder can also be switched to sound the third and fourth stage alarm tones.

The tone table (D221-95-001-IS) shows the switch positions for the 64 tones on first and second stages and which tones are available for the third and fourth stages dependent on the Stage 1 DIP switch setting.

Following table (Table 3) is a summary of wiring options.

Config.	Voltage	Configuration Description	Features	Product Option Identifier
See documents D190-06-001 for DC schematic diagrams.				
1a	DC	Single Stage Configuration	<ul style="list-style-type: none"> Line monitoring Positive Switching 	1
1b	DC	Two Stage Configuration	<ul style="list-style-type: none"> Common Negative Positive Switching 	1
1c	DC	Three/Four Stage Configuration	<ul style="list-style-type: none"> Common Negative Positive Switching 	1
2	DC	Three/Four Stages. Voltage Free 2nd, 3rd & 4th Stage Activation Configuration	<ul style="list-style-type: none"> Common Positive Customer Set H1 & H2 to Negative Switching 	1
3	DC	Two Stage Configuration	<ul style="list-style-type: none"> Independent Stage Input Reverse Polarity Stage Monitoring 	1
4	DC	Two Stage Configuration	<ul style="list-style-type: none"> Independent power input for alarm stage activation of Stage 1 & 2. Line monitoring available for each alarm stage – use suitable monitoring relays/modules. Line monitoring requires common negative between each power input. Line monitoring maximum voltage: 4Vdc. Not to be used for reverse polarity line monitoring. 	Y
5	DC	Two/Three Stage Voltage Free Activation Configuration		K
6	DC	Three/Four Stage Configuration	<ul style="list-style-type: none"> Independent power input for alarm stage activation of Stage 1, 2 and 3 Stage 4 can be activated via activation of Stage 2 and Stage 3 simultaneously Line monitoring available for Stage 1, 2 & 3 alarm stage – use suitable monitoring relays/modules Line monitoring requires common negative between each power input Line monitoring maximum voltage: 4Vdc Not to be used for reverse polarity line monitoring 	V
See documents D190-06-005 for AC schematic diagrams.				
1a	AC	Single Stage Configuration		1
1b	AC	Three/Four Stage Configuration		1
2	AC	Two/Three Stage Voltage Free Activation Configuration		K

Table 3: Summary of Wiring Options.

9) End of Line Monitoring (DC Units)

All DC units have a blocking diode fitted in their supply input lines. An end of line monitoring diode or an end of line monitoring resistor can be connected across the +ve and -ve terminals in the flameproof chamber. If an end of line resistor is used it must have a minimum resistance value of 3k3 ohms and a minimum wattage of 0.5W or a minimum resistance value of 500 ohms and a minimum wattage of 2W.

The resistor must be connected directly across the +ve and -ve terminals as shown in the following drawing. The resistor leads should be kept as short as possible. See D190-06-001 for details.

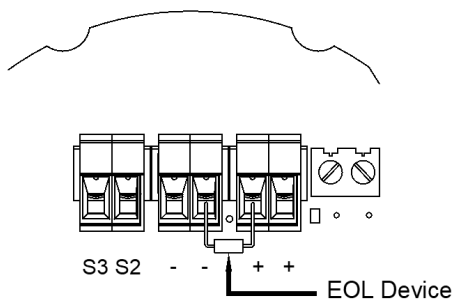

Figure 11: End of Line Resistor placement.

Note: For forward voltage polarity line monitoring the maximum voltage is 4Vdc. For wiring configuration 4 (product option Y) and configuration 6 (product option V) line monitoring requires common negative between each power input. For monitoring voltage, the installer should allow for system cabling and voltage drops

9.1 Custom DC Multi-Stage End Of Line Monitoring

An optional 12-way terminal module is available to enable up to four alarm stages to be activated from three DC voltage output channels. The three alarm stage activation inputs can be independently monitored.

Refer to Schematic D190-06-001, Config. 6.
Specify Product option 'V' when ordering.
Spare part code for field installation: SP78-0001

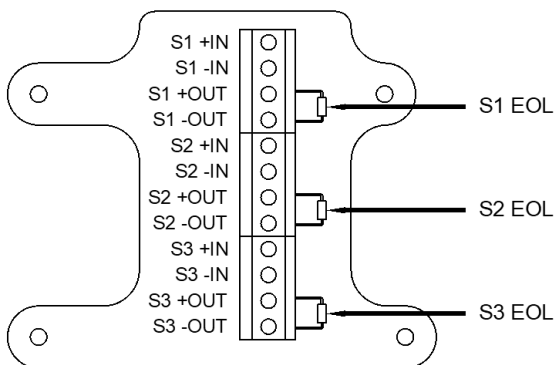

Figure 12: End of Line Resistor placement – Optional 12-Way Terminal Module.

10) Maintenance, Overhaul and Repair

Maintenance, repair and overhaul of the equipment should only be carried out by suitably qualified personnel in accordance with the current relevant standards:

EN60079-19/IEC60079-19

Explosive atmospheres – Equipment repair, overhaul and reclamation

EN 60079-17/IEC60079-17

Explosive atmospheres – Electrical installations inspection and maintenance

Flameproof threaded joints and cemented joints are not permitted to be repaired.

Units must not be opened while an explosive atmosphere is present.

If opening the unit during maintenance operations a clean environment must be maintained and any dust layer removed prior to opening the unit.

Electrostatic charging hazard - Clean only with a damp cloth.

11) SIL 2 Reliability Data

Reliability and Functional safety IEC/EN61508 which has been assessed and is considered suitable for use in low demand safety function:

1. Random Hardware Failures and Architectural constraints (route 2H).
2. As an unvoted item (i.e. hardware fault tolerance of 0) at SIL 2. The product was assessed against failure modes:
 - Failure respond to an input by sounding sounder.
 - Spurious sound output despite no input.
3. When employing the device in a SIL2 compliant system the user should ensure frequent or continuous automatic monitoring of continuity.

Integrity in respect of failure to function	SIL2 & SIL1
Total Failure rate	0.55 pmh
"Hazardous" failure rate (revealed)	0 pmh
"Hazardous" failure rate (unrevealed)	0.55 pmh
"Safe" failure rate (revealed)	0 pmh
"Safe" failure rate (unrevealed)	0
System type	B
Hardware Fault Tolerance	0
Diagnostic Coverage	>80%
PFD (hazardous failure)	2.4×10^{-3}
Proof Test Interval	Up to 1 year

1	2	3	4	5	6	7	8	9	10
							ISSUE	MOD No.	REASON - INITIAL - DATE
							1		INTRODUCTION RSR - 19/01/2022
							2	ACN0141	EOL VALUES AMENDED RSR - 20/12/2023
							3	ACN0153	OPTIONS Y & V MONITORING DETAILS RSR - 06/06/2024

OPTIONAL LINE MONITORING RESISTOR, CUSTOMER SUPPLIED,
MINIMUM EOL RESISTOR VALUES
500Ω MIN AT 2W MIN OR 3.3KΩ MIN AT 0.5W MIN



Single Stage Configuration	Config.: 1a	Two Stage Configuration	Config.: 1b	Three/Four Stage Configuration	Config.: 1c
Line Monitoring Set to positive switching (default)		Common Negative Set to positive switching (default)		Common Negative Set to positive switching (default)	
Stage 1: Apply Power to Stage 1 +ve & Stage 1 -ve		Stage 1: Apply Power to Stage 1 +ve & Common -ve Stage 2: Apply Power to Stage 2 +ve & Common -ve		Stage 1: Apply Power to Stage 1 +ve & Common -ve Stage 2: Apply Power to Stage 2 +ve & Common -ve Stage 3: Apply Power to Stage 3 +ve & Common -ve Stage 4: Apply Power to Stage 2 +ve, Stage 3 +ve & Common -ve	

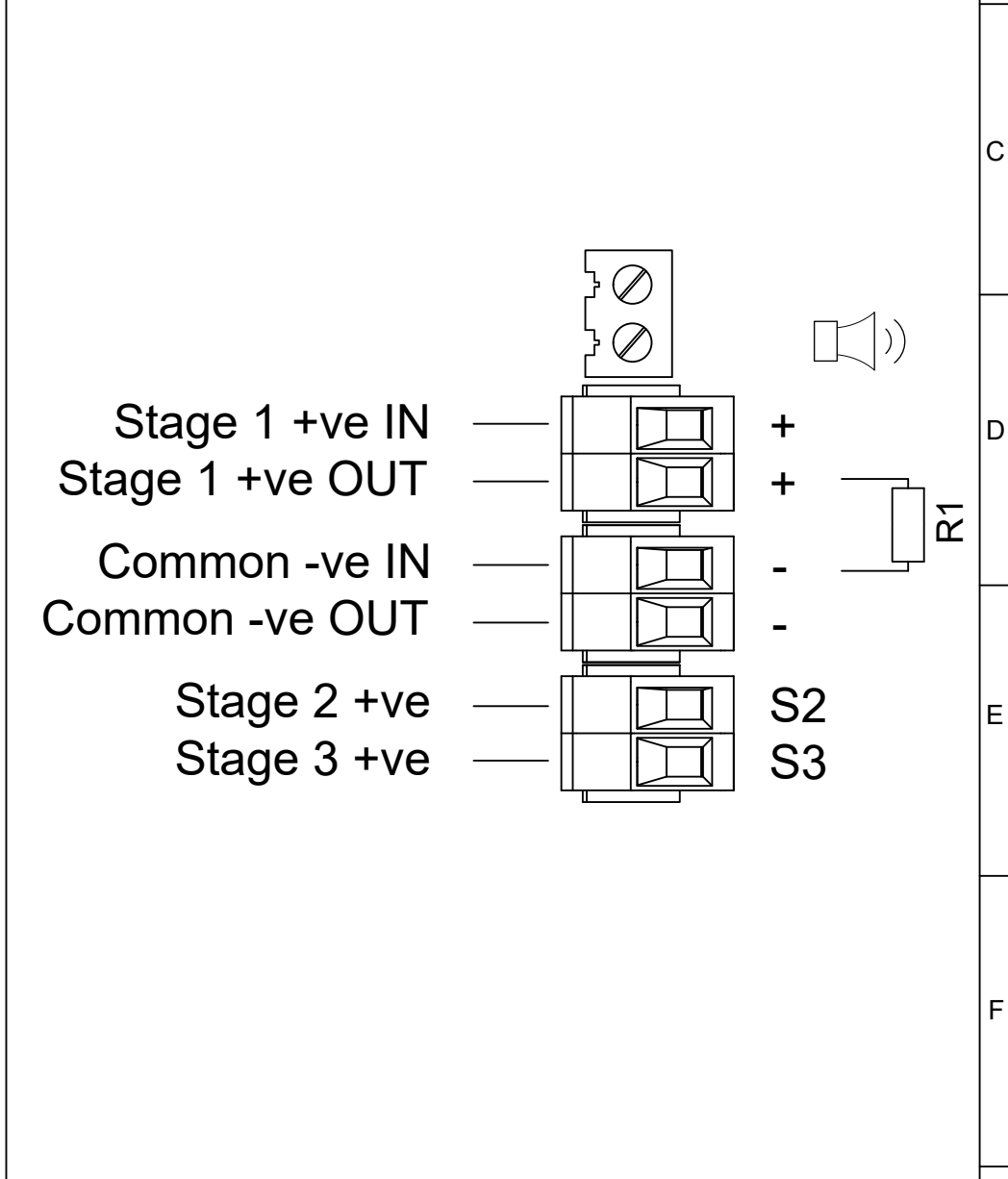
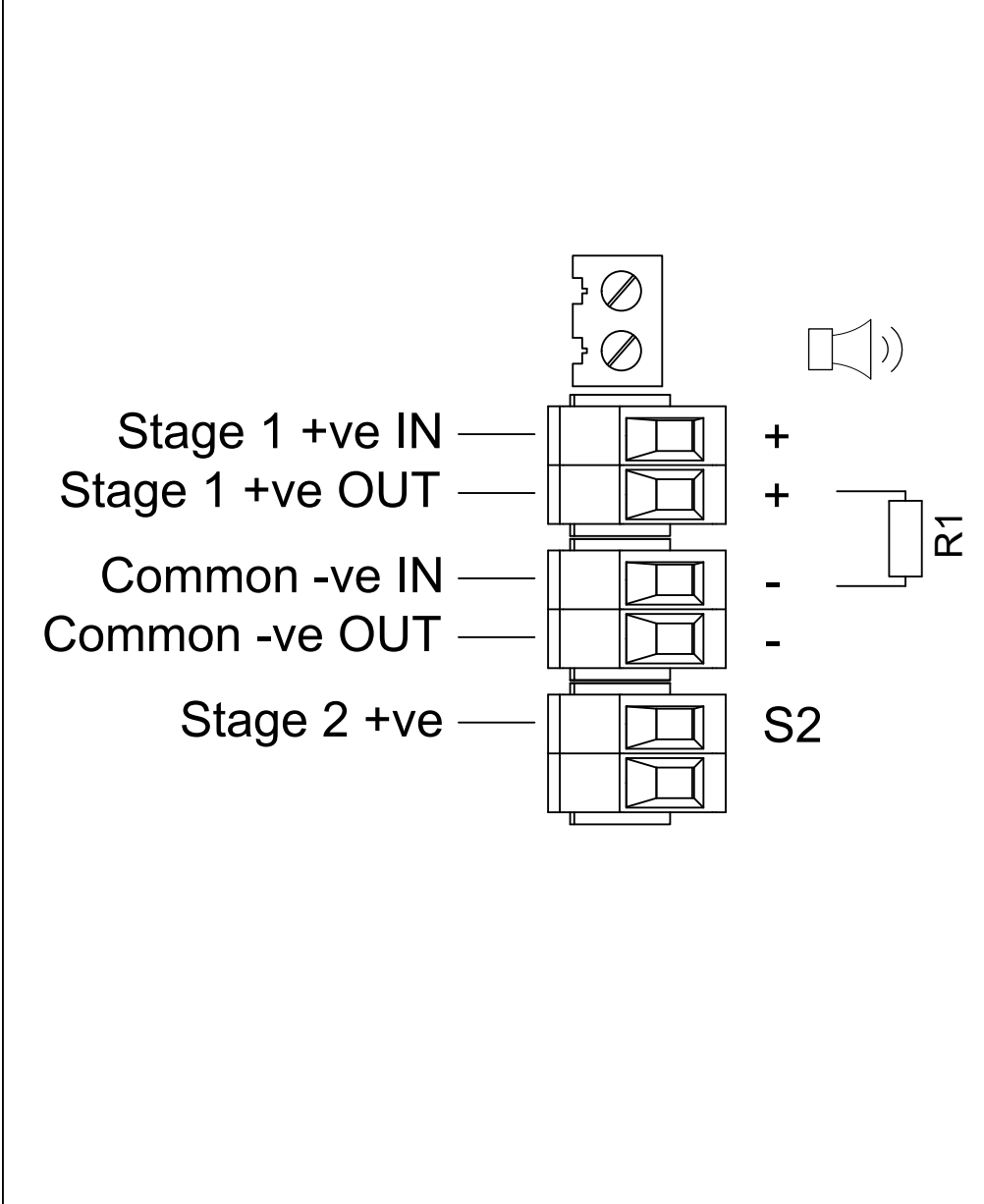
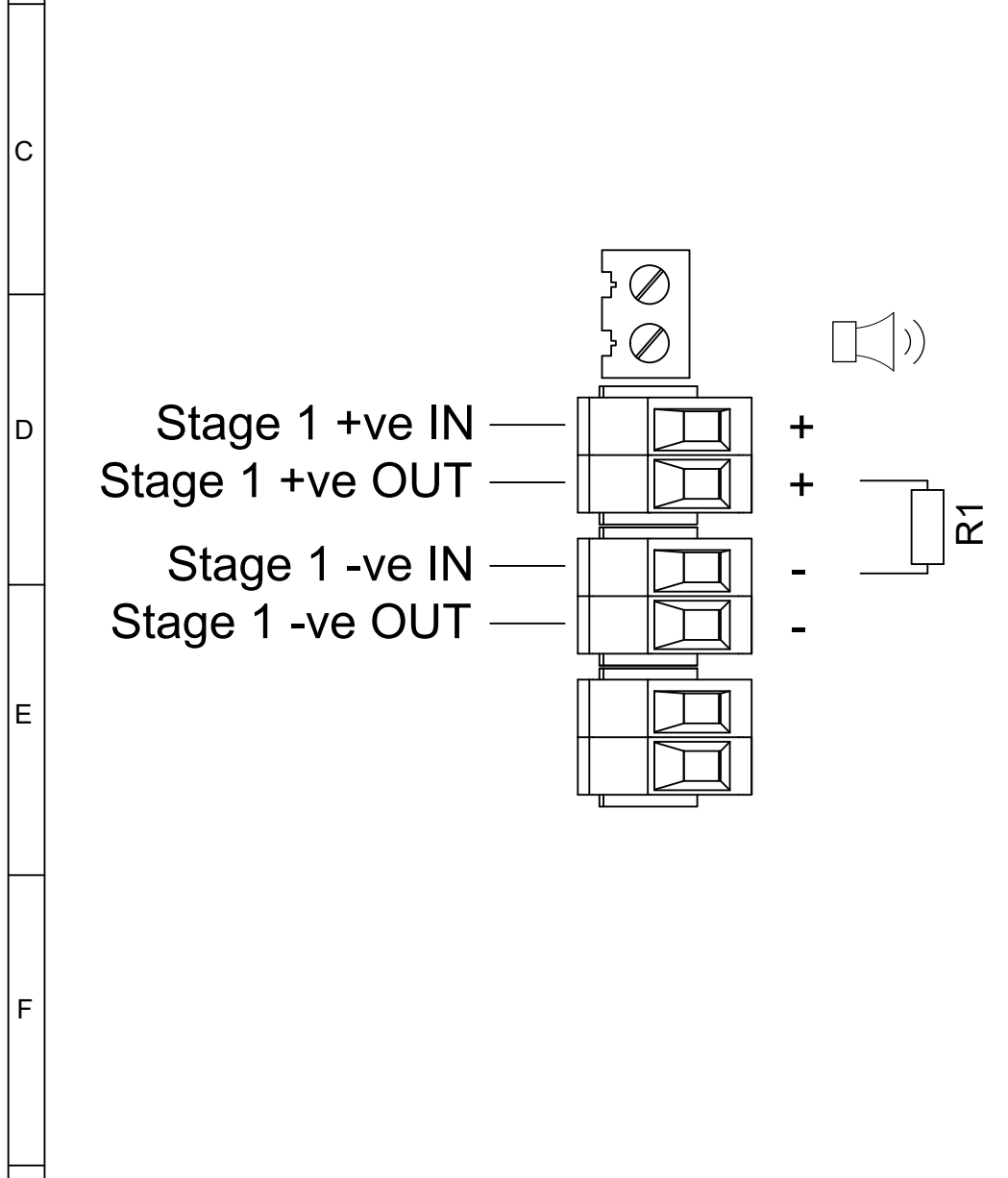

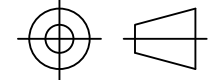
DRAWING TO BS8888:2000 GEOMETRIC TOLERANCES TO ISO1101:1983 LINEAR DIMENSIONAL TOLS ANGULAR DIMENSIONAL TOLS	DRAWN	DATE	SURFACE FINISH	WEIGHT (Kg)	THIS DRAWING AND ANY INFORMATION OR DESCRIPTIVE MATTER THEREIN IS COMMUNICATED IN CONFIDENCE AND IS THE COPYRIGHT PROPERTY OF EUROPEAN SAFETY SYSTEMS LTD. NEITHER THE WHOLE OR ANY EXTRACT MAY BE DISCLOSED, LOANED, COPIED OR USED FOR MANUFACTURING OR TENDERING PURPOSES WITHOUT THEIR WRITTEN CONSENT.	 EUROPEAN SAFETY SYSTEMS LTD IMPRESS HOUSE MANSELL ROAD ACTON LONDON W3 7QH WWW.E2S.COM	ALL DIMENSIONS IN MM IF IN DOUBT, ASK - DO NOT SCALE			A3
	R.S.RAIT	19/01/2022					MATERIAL	TITLE D1xS1 / D1xS2 / GNExS1 / GNExS2 / STExS1 / STExS2 DC SOUNDER WIRING DIAGRAMS		
	CHECKED	DATE	ALTERNATIVE MATERIAL	SCALE			SHEET	DRAWING NUMBER		
	B.ISARD	19/01/2022		NTS			1 OF 3	D190-06-001		
STANDARDS	APPROVED	DATE								
D1x	R.N.POTTS	19/01/2022								

1	2	3	4	5	6	7	8	9	10
							ISSUE	MOD No.	REASON - INITIAL - DATE
							1		INTRODUCTION RSR - 19/01/2022
							2	ACN0141	EOL VALUES AMENDED RSR - 20/12/2023
							3	ACN0153	OPTIONS Y & V MONITORING DETAILS RSR - 06/06/2024

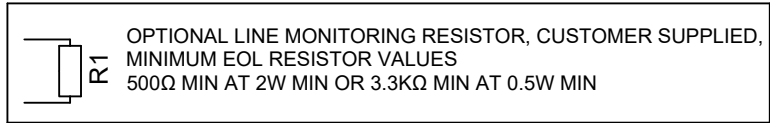

Three/Four Stages. Voltage Free 2nd, 3rd & 4th Stage Activation Configuration Config.: 2 Two Stage Configuration Config.: 3

Common Positive
Customer Set H1 & H2 to Negative Switching (See Below)

Independent Stage Input
Reverse Polarity Stage Monitoring

Stage 1: Apply Power to Common +ve & Stage 1 -ve
Stage 2: Apply Power to Common +ve & Stage 1 -ve & connect Stage 2 -ve to Stage 1 -ve
Stage 3: Apply Power to Common +ve & Stage 1 -ve & connect Stage 3 -ve to Stage 1 -ve
Stage 4: Apply Power to Common +ve & Stage 1 -ve
& connect Stage 2 -ve & Stage 3 -ve to Stage 1 -ve

Stage 1: Apply Power to Stage 1 +ve & Stage 1 -ve
Stage 2: Apply Power to Stage 1 +ve & Stage 1 -ve & connect Stage 2 -ve to Stage 1 -ve

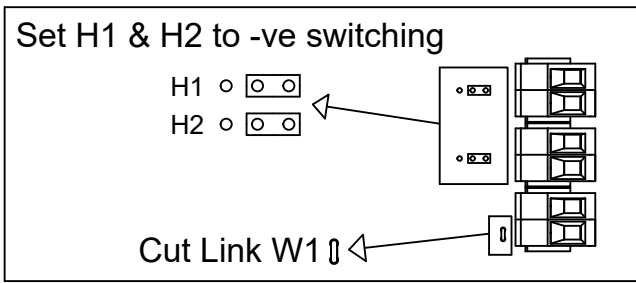
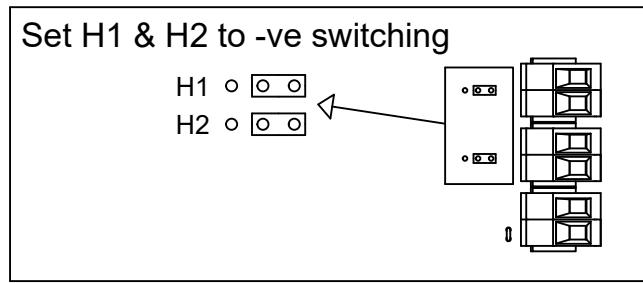
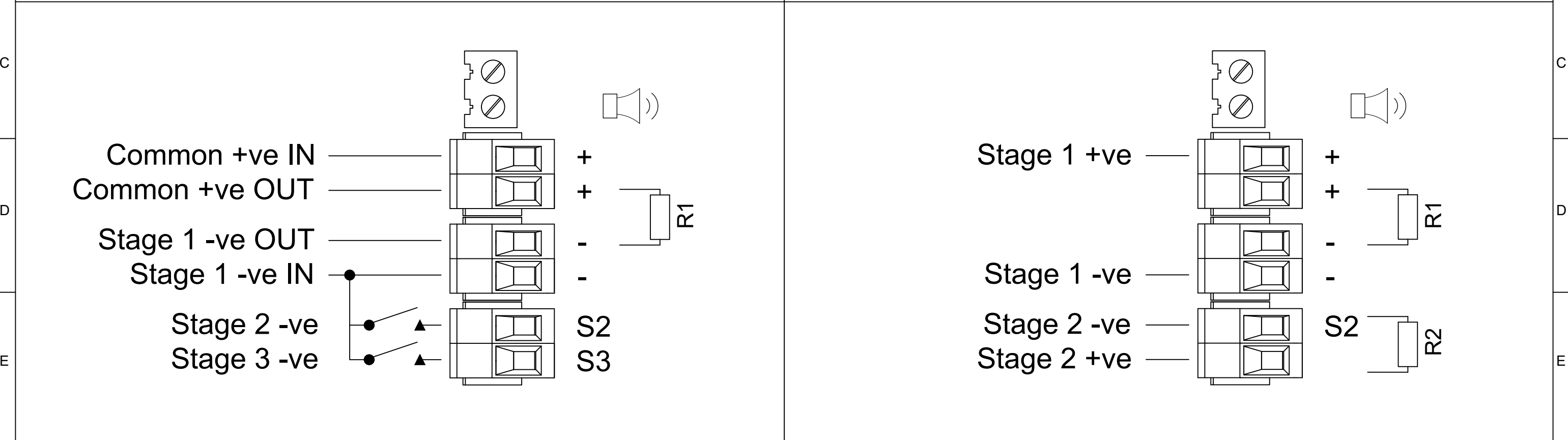

G	DRAWING TO BS8888:2000 GEOMETRIC TOLERANCES TO ISO1101:1983 LINEAR DIMENSIONAL TOLS ANGULAR DIMENSIONAL TOLS	DRAWN R.S.RAIT	DATE 19/01/2022	SURFACE FINISH	WEIGHT (Kg)	THIS DRAWING AND ANY INFORMATION OR DESCRIPTIVE MATTER THEREIN IS COMMUNICATED IN CONFIDENCE AND IS THE COPYRIGHT PROPERTY OF EUROPEAN SAFETY SYSTEMS LTD. NEITHER THE WHOLE OR ANY EXTRACT MAY BE DISCLOSED, LOANED, COPIED OR USED FOR MANUFACTURING OR TENDERING PURPOSES WITHOUT THEIR WRITTEN CONSENT. © EUROPEAN SAFETY SYSTEMS LTD. AS PER LATEST DATE OF ISSUE SHOWN ABOVE	 EUROPEAN SAFETY SYSTEMS LTD IMPRESS HOUSE MANSELL ROAD ACTON LONDON W3 7QH WWW.E2S.COM	ALL DIMENSIONS IN MM IF IN DOUBT, ASK - DO NOT SCALE		A3
	STANDARDS D1x	CHECKED B.ISARD	DATE 19/01/2022	MATERIAL	TITLE D1xS1 / D1xS2 / GNExS1 / GNExS2 / STExS1 / STExS2 DC SOUNDER WIRING DIAGRAMS					
		APPROVED R.N.POTTS	DATE 19/01/2022	ALTERNATIVE MATERIAL	SCALE NTS			SHEET 2 OF 3	DRAWING NUMBER D190-06-001	

1	2	3	4	5	6	7	8	9	10
							ISSUE	MOD No.	REASON - INITIAL - DATE
							1		INTRODUCTION RSR - 19/01/2022
							2	ACN0141	EOL VALUES AMENDED RSR - 20/12/2023
							3	ACN0153	OPTIONS Y & V MONITORING DETAILS RSR - 06/06/2024

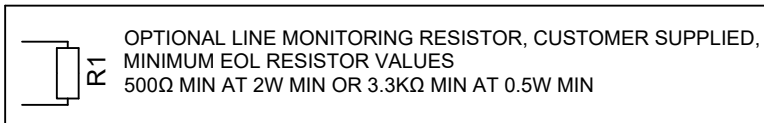

Two Stage Configuration			Config.: 4	Two/Three Stage Voltage Free Activation Configuration			Config.: 5	Three/Four Stage Configuration			Config.: 6
-------------------------	--	--	------------	---	--	--	------------	--------------------------------	--	--	------------

Independent power input for alarm stage activation. Line monitoring available for Stage 1 & 2 alarm stage. Line monitoring requires common negative between each power input. Line monitoring maximum voltage: 4Vdc. Not to be used for reverse polarity line monitoring.				Customer Set H1 & H2 to Negative Switching (See Below)				Independent power input for alarm stage activation. Line monitoring available for Stage 1, 2 & 3 alarm stage. Line monitoring requires common negative between each power input. Line monitoring maximum voltage: 4Vdc. Not to be used for reverse polarity line monitoring.			
---	--	--	--	--	--	--	--	--	--	--	--

Stage 1: Apply Power to Stage 1 +ve & Stage 1 -ve Stage 2: Apply Power to Stage 2 +ve & Stage 2 -ve				Power: +ve & -ve Stage 1: Connect Stage 1 -ve to Common -ve Stage 2: Connect Stage 2 -ve to Common -ve Stage 3: Connect both Stage 1 -ve & Stage 2 -ve to Common -ve				Stage 1: Apply Power to Stage 1 +ve & Stage 1 -ve Stage 2: Apply Power to Stage 2 +ve & Stage 2 -ve Stage 3: Apply Power to Stage 3 +ve & Stage 3 -ve Stage 4: Apply Power to Stage 2 +ve & Stage 2 -ve & Apply Power to Stage 3 +ve & Stage 3 -ve			
--	--	--	--	---	--	--	--	---	--	--	--

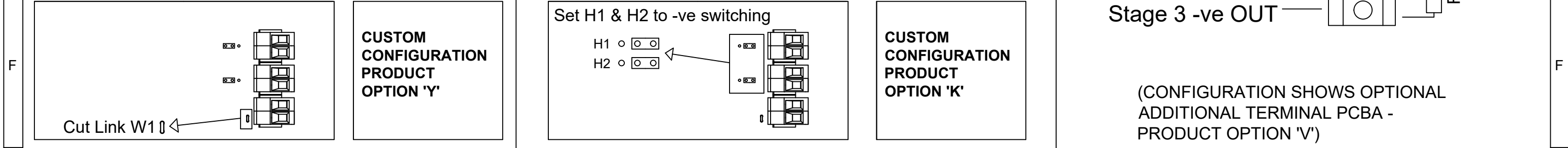
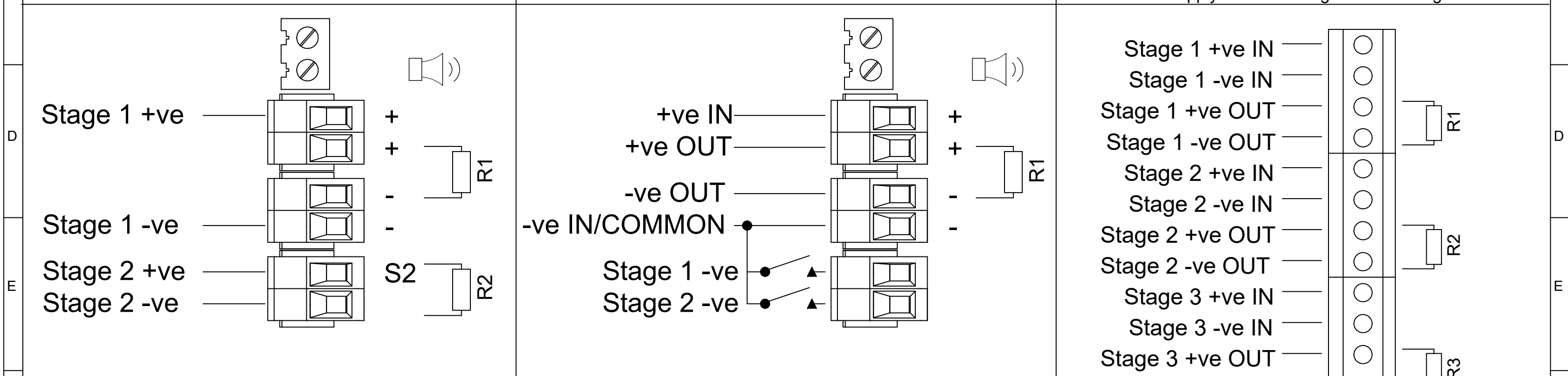

DRAWING TO BS8888:2000 GEOMETRIC TOLERANCES TO ISO1101:1983 LINEAR DIMENSIONAL TOLS ANGULAR DIMENSIONAL TOLS	DRAWN	DATE	SURFACE FINISH	WEIGHT (Kg)	THIS DRAWING AND ANY INFORMATION OR DESCRIPTIVE MATTER THEREIN IS COMMUNICATED IN CONFIDENCE AND IS THE COPYRIGHT PROPERTY OF EUROPEAN SAFETY SYSTEMS LTD. NEITHER THE WHOLE OR ANY EXTRACT MAY BE DISCLOSED, LOANED, COPIED OR USED FOR MANUFACTURING OR TENDERING PURPOSES WITHOUT THEIR WRITTEN CONSENT.	 EUROPEAN SAFETY SYSTEMS LTD IMPRESS HOUSE MANSELL ROAD ACTON LONDON W3 7QH WWW.E2S.COM	ALL DIMENSIONS IN MM IF IN DOUBT, ASK - DO NOT SCALE		 A3	
	CHECKED	DATE	MATERIAL				TITLE D1xS1 / D1xS2 / GNExS1 / GNExS2 / STExS1 / STExS2 DC SOUNDER WIRING DIAGRAMS			
	APPROVED	DATE	ALTERNATIVE MATERIAL				SCALE	SHEET		DRAWING NUMBER
STANDARDS	R.S.RAIT	19/01/2022					NTS	3 OF 3	D190-06-001	
D1x	B.ISARD	19/01/2022								
	R.N.POTTS	19/01/2022								



Single Stage Configuration	Config.: 1a	Three/Four Stage Configuration	Config.: 1b	Two Stage Voltage Free Activation Configuration	Config.: 2	
Stage 1: Apply Power to Stage 1 Live & Stage 1 Neutral		Stage 1: Apply Power to Live & Neutral Stage 2: Apply Power to Live & Neutral & connect Stage 2 to Common Stage 3: Apply Power to Live & Neutral & connect Stage 3 to Common Stage 4: Apply Power to Live & Neutral & connect both Stage 2 & Stage 3 to Common		Power: Live & Neutral Stage 1: Connect Stage 1 to Common Stage 2: Connect Stage 2 to Common Stage 3: Connect both Stage 1 & Stage 2 to Common		

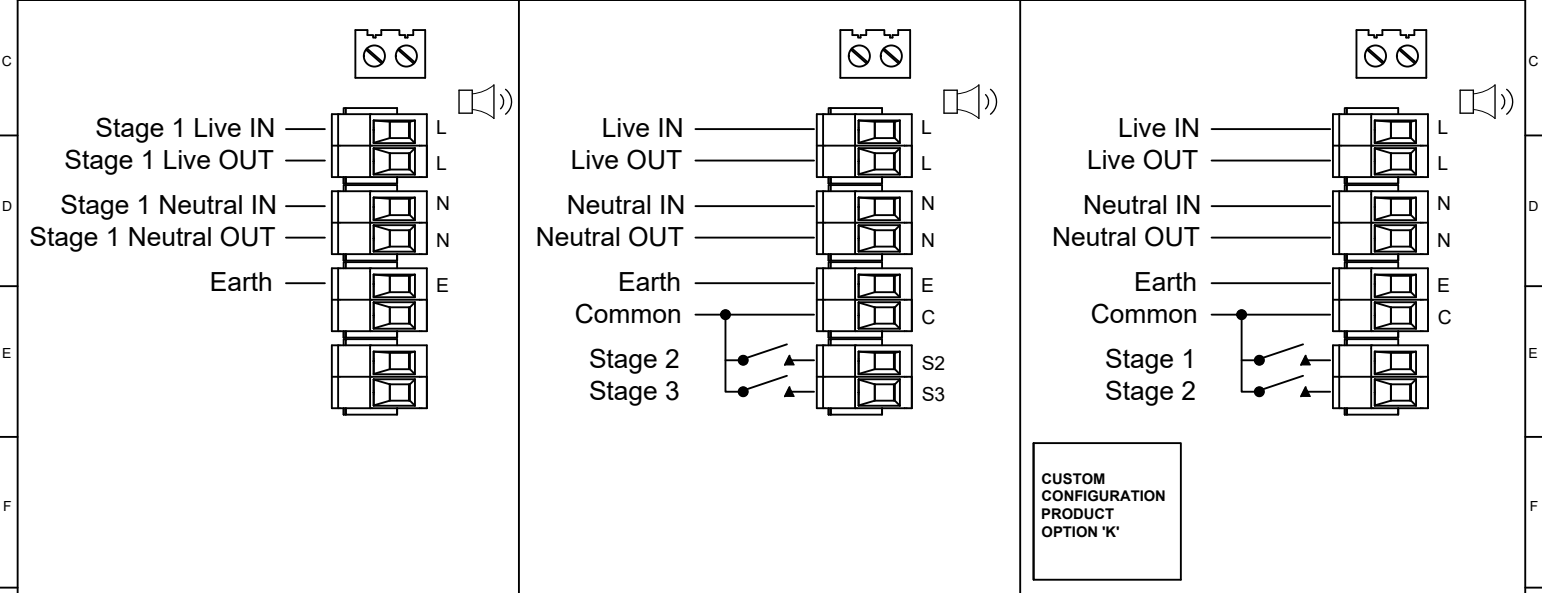

CUSTOM CONFIGURATION PRODUCT OPTION 'K'

DRAWING TO BS8888:2000 GEOMETRIC TOLERANCES TO ISO1101:1983 LINEAR DIMENSIONAL TOLS ANGULAR DIMENSIONAL TOLS	DRAWN	DATE	SURFACE FINISH	WEIGHT (Kg)	<small>THIS DRAWING AND ANY INFORMATION OR DESCRIPTIVE MATTER THEREIN IS COMMUNICATED IN CONFIDENCE AND IS THE COPYRIGHT PROPERTY OF EUROPEAN SAFETY SYSTEMS LTD. NEITHER THE WHOLE NOR ANY EXTRACT MAY BE DISCLOSED, LOANED, COPIED OR USED FOR MANUFACTURING OR TENDERING PURPOSES WITHOUT THEIR WRITTEN CONSENT.</small> EUROPEAN SAFETY SYSTEMS LTD. <small>AS PER LATEST DATE OF ISSUE SHOWN ABOVE</small>	 <small>EUROPEAN SAFETY SYSTEMS LTD IMPRESS HOUSE MANSELL ROAD LONDON W3 7QH WWW.E2S.COM</small>	ALL DIMENSIONS IN MM IF IN DOUBT, ASK - DO NOT SCALE	
	CHECKED	DATE	MATERIAL	TITLE D1xS1 / D1xS2 / GNExS1 / GNExS2 / STExS1 / STExS2 AC SOUNDER WIRING DIAGRAMS				
	STANDARDS	DATE	ALTERNATIVE MATERIAL	SCALE NTS			SHEET 1 OF 1	
	D1x	19/01/2022						
	B.ISARD	19/01/2022						
	R.N.POTTS	19/01/2022						

Stage 1 Set DIP SW 1 Tone No.	Tone Description	Tone Visual	Stage 1 & 2 DIP SW 1/2 Settings 1 2 3 4 5 6	Stage 3 Set DIP SW 1 (S3)	Stage 4 Set DIP SW 1 (S2 + S3)
1	1000Hz PFEER Toxic Gas		0 0 0 0 0	2	44
2	1200/500Hz @ 1Hz DIN /PFEER P.T.A.P.		1 0 0 0 0	3	44
3	1000Hz @ 0.5Hz(1s on, 1soff) PFEER Gen. Alarm		0 1 0 0 0 0	2	44
4	1.4KHz-1.6KHz 1s, 1.6KHz-1.4KHz 0.5s NF C 48-265		1 1 0 0 0 0	24	1
5	544Hz(100mS)/440Hz (400mS) NF S 32-001		0 0 1 0 0 0	19	1
6	1500/500Hz - (0.5s on , 0.5s off) x3 + 1s gap AS4428		1 0 1 0 0 0	44	1
7	500-1500Hz Sweeping 2 sec on 1 sec off AS4428		0 1 1 0 0 0	44	1
8	500/1200Hz @ 0.26Hz (3.3son, 0.5s off) Netherlands - NEN 2575		1 1 1 0 0 0	24	35
9	1000Hz (1s on, 1s off)x7 + (7s on, 1s off) IMO Code 1a		0 0 0 1 0 0	34	1
10	1000Hz (1s on, 1s off)x7 + (7s on, 1s off) IMO Code 1a		1 0 0 1 0 0	34	1
11	420Hz(0.5s on, 0.5s off)x3 + 1s gap ISO 8201 Temporal Pattern		0 1 0 1 0 0	1	8
12	1000Hz(0.5s on, 0.5s off)x3 + 1s gap ISO 8201 Temporal Pattern		1 1 0 1 0 0	1	8
13	422/775Hz - (0.85 on, 0.5 off) x3 + 1s gap NFPA - Temporal Coded		0 0 1 1 0 0	1	8
14	1000/2000Hz @ 1Hz Singapore		1 0 1 1 0 0	3	35
15	300Hz Continuous (f=300)		0 1 1 1 0 0	24	35
16	440Hz Continuous (f=440)		1 1 1 1 0 0	24	35
17	470Hz Continuous (f=470)		0 0 0 0 1 0	24	35
18	500Hz Continuous IMO code 2 (Low) (f=500)		1 0 0 0 1 0	24	35
19	554Hz Continuous (f=554)		0 1 0 0 1 0	24	35
20	660Hz Continuous (f=660)		1 1 0 0 1 0	24	35
21	800Hz IMO code 2 (High) (f=800)		0 0 1 0 1 0	24	35
22	1200Hz Continuous (f=1200)		1 0 1 0 1 0	24	35
23	2000Hz Continuous (f=2000)		0 1 1 0 1 0	3	35
24	2400Hz Continuous (f=2400)		1 1 1 0 1 0	20	35
25	440Hz @0.83Hz (50 cycles/minute) Intermittent (f=440, a=0.6, b=0.6)		0 0 0 1 1 0	44	8
26	470Hz @0.9Hz - 1.1s Intermittent (f=470, a=0.55, b=0.55)		1 0 0 1 1 0	44	8
27	470Hz @5Hz - (5 cycles/second) Intermittent (f=470, a=0.1, b=0.1)		0 1 0 1 1 0	44	8
28	544Hz @ 1.14Hz - 0.875s Intermittent (f=470, a=0.43, b=0.44)		1 1 0 1 1 0	24	8
29	655Hz @ 0.875Hz Intermittent (f=655, a=0.57, b=0.57)		0 0 1 1 1 0	44	8
30	660Hz @0.28Hz - 1.8sec on, 1.8sec off Intermittent (f=660, a=1.8, b=1.8)		1 0 1 1 1 0	24	8
31	660Hz @3.34Hz - 150mS on, 150mS off Intermittent (f=660, a=0.15, b=0.15)		0 1 1 1 1 0	24	8
32	745Hz @ 1Hz Intermittent (f=745, a=0.5, b=0.5)		1 1 1 1 1 0	24	8
33	800Hz - 0.25sec on, 1 sec off Intermittent (f=800, a=0.25, b=1)		0 0 0 0 0 1	24	8
34	800Hz @ 2Hz IMO code 3.a (High) Intermittent (f=800, a=0.25, b=0.25)		1 0 0 0 0 1	24	8
35	1000Hz @ 1Hz Intermittent (f=1000, a=0.5, b=0.5)		0 1 0 0 0 1	24	8
36	2400Hz @ 1Hz Intermittent (f=2400, a=0.5, b=0.5)		1 1 0 0 0 1	24	8
37	2900Hz @ 5Hz Intermittent (f=2900, a=0.1, b=0.1)		0 0 1 0 0 1	24	8
38	363/518Hz @ 1Hz Alternating (f=363, f1=518, a=0.1)		1 0 1 0 0 1	8	19
39	450/500Hz @ 2Hz Alternating (f=450, f1=500, a=0.25)		0 1 1 0 0 1	8	19
40	554/440Hz @ 1Hz Alternating (f=440, f1=554, a=0.5)		1 1 1 0 0 1	24	19
41	554/440Hz @ 0.625Hz Alternating (f=440, f1=554, a=0.8)		0 0 0 1 0 1	8	19
42	561/760Hz @0.83Hz (50 cycles/minute) Alternating (f=561, f1=760, a=0.6)		1 0 0 1 0 1	8	19
43	780/600Hz @ 0.96Hz Alternating (f=600, f1=780, a=0.52)		0 1 0 1 0 1	8	19
44	800/1000Hz @ 2Hz Alternating (f=800, f1=1000, a=0.25)		1 1 0 1 0 1	24	19
45	970/800Hz @ 2Hz Alternating (f=800, f1=970, a=0.25)		0 0 1 1 0 1	8	19
46	800/1000Hz @ 0.875Hz Alternating (f=800, f1=1000, a=0.57)		1 0 1 1 0 1	24	19
47	2400/2900Hz @ 2Hz Alternating (f=2400, f1=2900, a=0.25)		0 1 1 1 0 1	24	19
48	500/1200Hz @ 0.3Hz Sweeping (f=500, f1=1200, a=3.34)		1 1 1 1 0 1	24	12
49	560/1055Hz @ 0.18Hz Sweeping (f=560, f1=1055, a=5.47)		0 0 0 0 1 1	24	12
50	560/1055Hz @ 3.3Hz Sweeping (f=560, f1=1055, a=0.3)		1 0 0 0 1 1	24	12
51	600/1250Hz @ 0.125Hz Sweeping (f=600, f1=1250, a=8)		0 1 0 0 1 1	24	12
52	660/1200Hz @ 1Hz Sweeping (f=660, f1=1200, a=1)		1 1 0 0 1 1	24	12
53	800/1000Hz @ 1Hz Sweeping (f=800, f1=1000, a=1)		0 0 1 0 1 1	24	12
54	800/1000Hz @ 7Hz Sweeping (f=800, f1=1000, a=0.14)		1 0 1 0 1 1	24	12
55	800/1000Hz @ 50Hz Sweeping (f=800, f1=1000, a=0.02)		0 1 1 0 1 1	24	12
56	2400/2900Hz @ 7Hz Sweeping (f=2400, f1=2900, a=0.14)		1 1 1 0 1 1	24	12
57	2400/2900Hz @ 1Hz Sweeping (f=2400, f1=2900, a=1)		0 0 0 1 1 1	24	12
58	2400/2900Hz @ 50Hz Sweeping (f=2400, f1=2900, a=0.02)		1 0 0 1 1 1	24	12
59	2500/3000Hz @ 2Hz Sweeping (f=2500, f1=3000, a=0.5)		0 1 0 1 1 1	24	12
60	2500/3000Hz @ 7.7Hz Sweeping (f=2500, f1=3000, a=0.13)		1 1 0 1 1 1	24	12
61	800Hz Motor Siren (f=800, a=1.6)		0 0 1 1 1 1	24	12
62	1200Hz Motor Siren (f=1200, a=2)		1 0 1 1 1 1	24	12
63	2400Hz Motor Siren (f=2400, a=1.7)		0 1 1 1 1 1	24	12
64	Simulated Bell		1 1 1 1 1 1	21	12

Page left Intentionally blank

EU Declaration of Conformity



Manufacturer: European Safety Systems Ltd.
Impress House, Mansell Road, Acton
London, W3 7QH
United Kingdom

Authorised Representative: E2S Warnsignaltechnik UG
Charlottenstrasse 45-51
72764 Reutlingen
Germany

Equipment Type: GNExS1, GNExS2
GNExL1, GNExL2

Directive 2014/34/EU: Equipment and Protective Systems for use in Potentially Explosive Atmospheres (ATEX)

Notified Body for EU type Examination (Module B):	Sira Certification Service Notified Body No.: 2813 CSA Group Netherlands B.V, Utrechtseweg 310, 6812 AR, Arnhem, Netherlands
EU-type Examination Certificate (Module B):	Sira 13ATEX1139X
Notified Body for Quality Assurance Notification / Conformity to EU-type based on quality assurance of the production process (Module D):	Sira Certification Service Notified Body No.: 2813 CSA Group Netherlands B.V, Utrechtseweg 310, 6812 AR, Arnhem, Netherlands
Quality Assurance Notification (Module D):	SIRA 05 ATEX M342
Provisions fulfilled by the equipment:	II 2G Ex db IIB or IIC T3, T4, T5 or T6 Gb
Standards applied:	EN 60079-0:2018 EN 60079-1:2014 A/C:2018

Directive 2014/30/EU: Electromagnetic Compatibility Directive (EMC)

Standards applied:	EN 61000-6-1:2007 EN 61000-6-2:2005 EN 61000-6-3:2007 / A1:2011 / AC: 2012 EN 61000-6-4:2007 / A1: 2011
--------------------	--

Directive 2011/65/EU: Restriction of the use of certain hazardous substances in electrical and electronic equipment (RoHS)

The product and all the components contained within it are in accordance with the restriction of the use of hazardous substances in electrical and electronic equipment, including amendment by Directive 2015/863/EU.

Regulation (EC) 1907/2006: Registration, Evaluation, Authorisation and Restriction of Chemicals (REACH)

The product and all the components contained within it are free from substances of very high concern.

Other Standards and Regulations

EN 60529:1992+A2:2013 - Degrees of protection provided by enclosures (IP code) – enclosure rated IP66/67

EU Declaration of Conformity



On behalf of European Safety Systems Ltd., I declare that, on the date the equipment accompanied by this declaration is placed on the market, the equipment conforms with all technical and regulatory requirements of the above listed directives, regulations and standards.

This Declaration is issued under the sole responsibility of the manufacturer.

A handwritten signature in black ink, appearing to read 'Martin Streetz'.

Martin Streetz
Quality Assurance Manager

Document No.:
Date and Place of Issue:

DC-038_Issue_F
London, 23/12/2020

Manufacturer: European Safety Systems Ltd.
 Impress House, Mansell Road, Acton
 London, W3 7QH
 United Kingdom

Equipment Type: GNExS1, GNExS2
 GNExL1, GNExL2

Directive UKSI 2016:1107 (as amended by UKSI 2019:696) – Schedule 3A, Part 1 : Product or Protective System Intended for use in Potentially Explosive Atmospheres (UKCA)

Notified Body for UK type Examination (Module B):	Sira Certification Service Notified Body No.: 0518 Rake Lane, Eccleston, Chester CH4 9JN, UK
UK-type Examination Certificate (Module B):	CSAE 21UKEX1558X
Notified Body for Quality Assurance Notification / Conformity to EU-type based on quality assurance of the production process (Module D):	Sira Certification Service Notified Body No.: 0518 Rake Lane, Eccleston, Chester CH4 9JN, UK
Quality Assurance Notification (Module D):	CSAE 22UKQAN0046
Provisions fulfilled by the equipment:	II 2G Ex db IIB or IIC T3, T4, T5 or T6 Gb
Standards applied:	EN 60079-0:2018 EN 60079-1:2014 A/C:2018

Directive 2014/30/EU: Electromagnetic Compatibility Directive (EMC)

Standards applied:	EN 61000-6-1:2007 EN 61000-6-2:2005 EN 61000-6-3:2007 / A1:2011 / AC: 2012 EN 61000-6-4:2007 / A1: 2011
--------------------	--

Directive 2011/65/EU: Restriction of the use of certain hazardous substances in electrical and electronic equipment (RoHS)

The product and all the components contained within it are in accordance with the restriction of the use of hazardous substances in electrical and electronic equipment, including amendment by Directive 2015/863/EU.

Regulation (EC) 1907/2006: Registration, Evaluation, Authorisation and Restriction of Chemicals (REACH)

The product and all the components contained within it are free from substances of very high concern.

Other Standards and Regulations

EN 60529:1992+A2:2013 - Degrees of protection provided by enclosures (IP code) – enclosure rated IP66/67

On behalf of European Safety Systems Ltd., I declare that, on the date the equipment accompanied by this declaration is placed on the market, the equipment conforms with all technical and regulatory requirements of the above listed directives, regulations and standards.

This Declaration is issued under the sole responsibility of the manufacturer.



Martin Streetz
 Quality Assurance Manager

Document No.: DC-095_Issue_A
 Date and Place of Issue: London, 04/02/2022